

TATA STEEL



Design of welded joints

Celsius[®]355 and Hybox[®]355



CONTENTS

1	Introduction	03
1.1	Product specification	04
2	Scope	05
2.1	Joint geometry	05
2.2	Multi-planar joints	08
2.3	Force and moment interaction	09
3	General design guidance	11
3.1	Structural analysis	11
3.2	Welding	13
3.3	Fabrication	16
4	Parameters affecting joint resistance	17
4.1	General	17
4.2	Joint failure modes	17
4.3	Parameter effects	20
4.4	Joint reinforcement	22
5	Joint design formulae	27
5.1	Circular chord joints	27
5.2	Knee joints in circular hollow sections	34
5.3	Rectangular chord joints	38
5.4	Knee joints in rectangular hollow sections	48
5.5	Unidirectional K- and N-joints	51
5.6	KT-joints	55
5.7	I- or H-section chord joints	58
6	List of symbols	63
6.1	General alphabetic list – upper case	63
6.2	General alphabetic list – lower case	64
6.3	Greek list	66
6.4	Suffix list	67
6.5	Pictorial list	68
7	References	70
7.1	Publications	70
7.2	Useful websites	71

1 INTRODUCTION

A properly designed steel construction using structural hollow sections will nearly always be lighter in material weight than one made with open section profiles. This publication shows how this is achieved through joint design. It also covers how the joint resistance is calculated and how it can be affected by both the geometric layout and sizing of the members.

Structural hollow sections have a higher strength to weight ratio than open section profiles, such as I-, H- and L- sections. They also require a much smaller weight of protection material because of their lower external area. Even though they are more expensive than open section profiles on a per tonne basis, the overall weight saving of steel and protective coatings will very often result in a much more cost effective solution.

Member sizing has a direct effect on both the joint resistance and the cost of fabrication because structural hollow sections are generally welded directly to each other. In order to obtain a technically secure, economic and architecturally pleasing structure, the architect and design engineer must be aware of the effects that their design decisions will have on the joint resistance, fabrication, assembly and the erection.

Considerable international research into the behaviour of lattice type welded joints has enabled design recommendations that include the large majority of manufactured structural hollow sections. These design recommendations were developed by CIDECT (Comité International pour la Développement et l'Étude de la Construction Tubulaire) and the IIW (International Institute of Welding). They have been used in a series of CIDECT Design Guides [1, 2] and are now incorporated into EN 1993-1-8:2005 [3].

Throughout this publication, the following terms are used:

- Circular – Circular Hollow Section or CHS
- Rectangular – Rectangular Hollow Section or RHS
- Square – Square Hollow Section or SHS

Please note:

- Refer to EN 1993-1-8:2005 local National Annex [4] for partial safety factors applied to the formulae.
- Where no known design recommendations exist, suggested methods are shown based on our knowledge and experience of structural hollow sections.
- The joint resistance formulae, reproduced in section 5, were developed and are presented in an ultimate limit state form and are therefore fully compatible with the requirements of Eurocode 3 and BS 5950-1:2000 [6].
- The symbols used are generally in line with EN 1993-1-8:2005 [3].
- The design recommendations can be used with **Celsius® 355** hot-finished structural hollow sections to EN 10210 [8, 9] and **Hybox® 355** cold-formed structural hollow sections to EN 10219 [10, 11].

1.1 Product specification

We offer two types of structural hollow section: **Celsius® 355** and **Hybox® 355**.

- **Celsius® 355** hot-formed structural hollow sections are produced by Tata Steel and fully comply with EN 10210 S355J2H [8, 9]. All **Celsius® 355** have an improved corner profile of 2t maximum⁽¹⁾. For full details see 'Celsius® 355 Technical Guide' [12].
Jumbo™ 355 hot finished structural hollow sections are supplied in association with Nakajima Steel Pipe Company and are part of the **Celsius® 355** range. They are supplied in accordance with EN 10210 S355J2H [8, 9]. For full details see 'Jumbo™ 355 Technical Guide' [17].
- **Hybox® 355** fully complies with EN 10219 S355J2H [10, 11]. For full details see 'Hybox® 355 Technical Guide' [13].

Open sections specified are to the Advance™ range complying with EN 10025-2: 2004 [7]. For full details see 'Advance™ sections' [14].

All these products are acceptable for applying the formulae in section 5 and are supplied with full certification suitable for use in construction (Type 3.1 inspection certificate).

(1) Excluding RHS 300 x 150 & SHS 150 x 150 x 16 which is up to 3t in accordance with EN 10210-2 [9].

2 SCOPE

This publication has been written mainly for plane frame girder joints under predominantly static axial and/or moment forces. However, there is some advice on non-planar frame joints.

Note:

Calculations in this publication use the convention that compressive forces and stresses are positive (+) and tensile ones are negative (-), in accordance with EN 1993-1-8 [3].

2.1 Joint geometry

The main types of joint configuration covered in this publication are shown in **figure 1**. Also discussed are other types of connections to structural hollow section main members, such as gusset plates.

The angle between the chord and a bracing or between two bracings should be between 30° and 90° inclusive. If the angle is less than 30° then:

- The designer must ensure that a structurally adequate weld can be made in the acute angle
- The joint resistance calculation should be made using an angle of 30° instead of the actual angle

When K- or N-joints with overlapping bracings are being used (**figure 2**), the overlap must be made with:

- Partial overlap where the first bracing runs through to the chord, and the second bracing sits on both the chord and the first bracing, or
- Sitting fully on the first bracing.

The joint should never be made by cutting the toes from each bracing and butting them up together (**figure 2b**). This is both more difficult to fit together and can result in joint resistances up to 20% lower than those calculated by the joint design formulae given in section 5. However, a modified version of the type of joint shown in **figure 2b** can be used, provided that a plate of sufficient thickness is inserted between the two bracings (section 4.4.3 on rectangular chord overlap joint reinforcement).

Figure 1:

Joint types

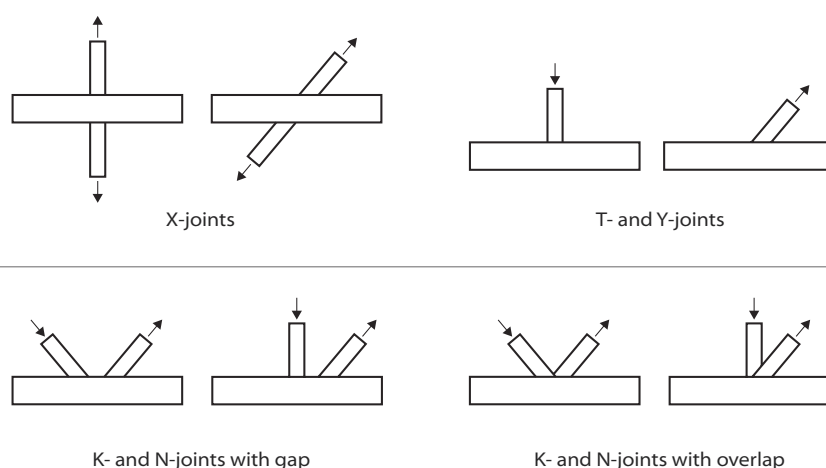
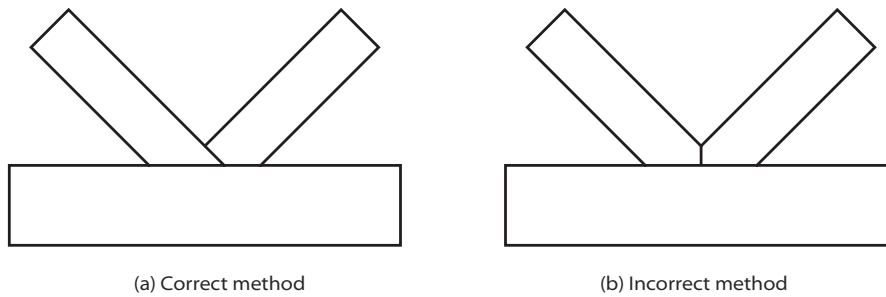

Figure 2:

Method of overlapping bracings



2.1.1 Validity ranges

In section 5 validity ranges are given for various geometric parameters of the joints. These validity ranges have been set to ensure that the modes of failure of the joints fall within the experimentally proven limits of the design formulae. If joints fall outside of these limits, other failure modes, not covered by the formulae, may become critical. As an example, no check is required for chord shear in the gap between the bracings of circular K- and N-joints, but this failure mode could become critical outside the validity limits given. However, if just one of these validity limits is *slightly* violated and all the other geometric parameters are *well inside* the limits of the joint, then we would suggest that the actual joint resistance could be reduced to about 0.85 times the calculated resistance using the design formulae.

Celsius® 355 Large circular hollow section range chords can cause the d_0/t_0 validity limit to be exceeded. To enable the joint resistance formulae to be applied, a reduced design yield, $f_{y0,r}$ can be used to replace f_{y0} in the formulae, but with the 0.85 times reduction as above as a minimum;

To EN 1993-1-1:2005:

Limited to Class 2 limiting proportions:

$$d/t \leq 70 \times 235/f_y$$

$$f_{y0,r} = \frac{16450 t_0}{d_0} \text{ but } f_{y0,r} \leq 0.85 f_{y0}$$

To BS 5950-1:2000:

Limited to Class 3 limiting proportions:

$$d/t \leq 80 \times 275/f_y$$

$$f_{y0,r} = \frac{22000 t_0}{d_0} \text{ but } f_{y0,r} \leq 0.85 f_{y0}$$

2.1.2 Joint symbols

A list of all the symbols used in this publication is given in section 6, but the main geometric symbols for the joint are shown below in **figure 3**. These symbols are constant in various publications but symbols used for other terms in the formulae may vary. This publication uses the same symbols as EN 1993-1-8 [3].

Figure 3:

Joint geometric symbols

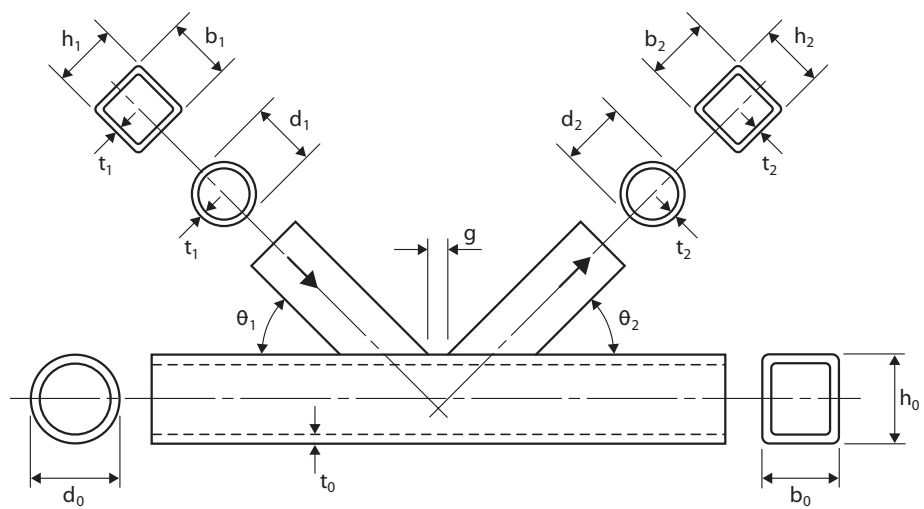

Circular and rectangular chord symbols

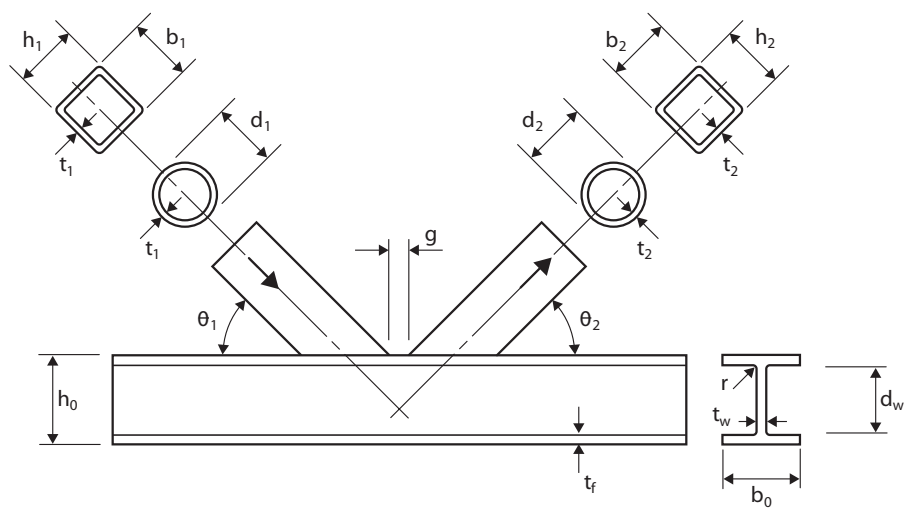

I- or H-chord symbols

2.2 Multi-planar joints

Multi-planar joints are typically found in triangular and box girders. By applying the multi-planar factor, μ (**figure 4**) to the calculated chord face deformation, you can use the same design formulae as planar joints. The factors shown in **figure 4** have been determined for angles between the planes of 60° to 90°.

Additionally, the chord must be checked for the combined shear from the two sets of bracings. As well as KK-joints this is also applicable to XX-joints where the bracing angle and geometry produce a gap between the bracing toes (**figure 4**). For rectangular chords, ensure the correct shear area is considered. This is dependant upon which chord faces are in shear.

To determine whether a joint should be considered as a multi-planar or a single planar joint refer to **figure 5**.

Figure 4:

Multi-planar factors

Joint type		Circular chords	Rectangular chords
TT-joint		$\mu = 1.0$	$\mu = 0.9$
XX-joint	<p>N_1 & N_2 can be all compression, all tension or a combination</p> 	$\mu = 1 + 0.33(N_{2,Ed}/N_{1,Ed})$	$\mu = 0.9(1 + 0.33(N_{2,Ed}/N_{1,Ed}))$
		<p>Taking account of the sign (+ or -) and with $N_{2,Ed} \leq N_{1,Ed}$</p> <p>Where a gap between toes of opposite bracings is formed, at section 1-1, check the chord satisfies:</p> $\left[\frac{N_{0,gap,Ed}}{N_{pl,0,Rd}} \right]^2 + \left[\frac{V_{0,Ed}}{V_{pl,0,Rd}} \right]^2 \leq 1.0$	
KK-joint	<p>N_1 is compression & N_2 is tension</p> 	<p>$\mu = 0.9$</p> <p>For gap joints, at section 1-1, check the chord satisfies:</p> $\left[\frac{N_{0,gap,Ed}}{N_{pl,0,Rd}} \right]^2 + \left[\frac{V_{0,Ed}}{V_{pl,0,Rd}} \right]^2 \leq 1.0$	

Figure 5:

Multi-planar joints

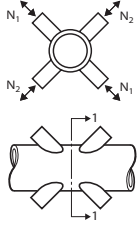
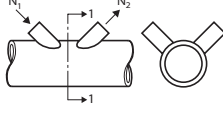
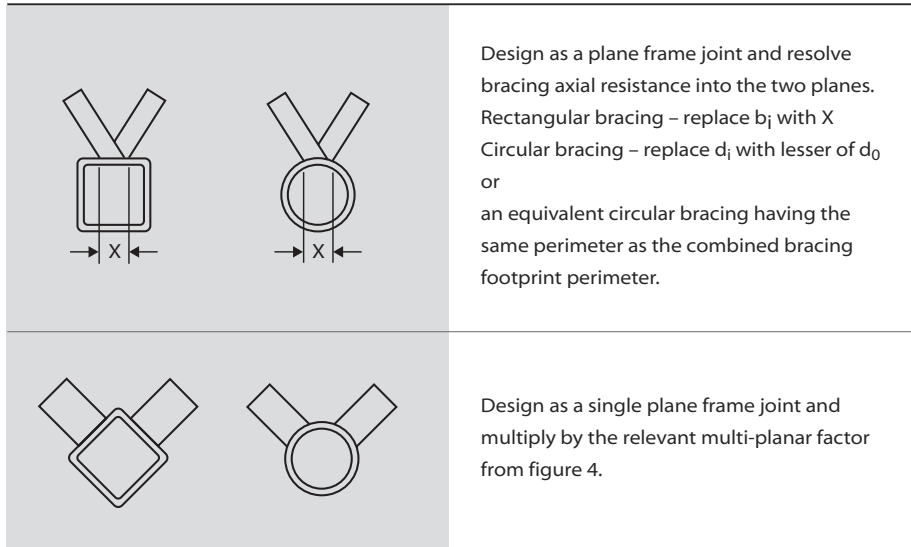

2.3 Force and moment interaction

If primary bending moments and axial forces are present in the bracings at a joint, then you must take into account the interaction effect using the following formulae:

For circular chord joints the interaction formula is:

$$\frac{|N_{i,Ed}|}{N_{i,Rd}} + \left[\frac{|M_{ip,i,Ed}|}{M_{ip,i,Rd}} \right]^2 + \frac{|M_{op,i,Ed}|}{M_{op,i,Rd}} \leq 1.0$$

For rectangular, I- and H-chord joints the interaction formula is:

$$\frac{|N_{i,Ed}|}{N_{i,Rd}} + \frac{|M_{ip,i,Ed}|}{M_{ip,i,Rd}} + \frac{|M_{op,i,Ed}|}{M_{op,i,Rd}} \leq 1.0$$



3 GENERAL DESIGN GUIDANCE

3.1 Structural analysis

Traditionally, the design of lattice structures is based on pin-jointed frames, with their members in tension or compression and the forces nodding (meeting at a common point) at the centre of each joint. The usual practice is to arrange the joint so that the centre line of the bracing members intersects on the centre line of the chord member **Figure 6**.

The member sizes are determined in the normal way to carry the design forces and the welds at the joint transfer the forces between members. A lattice girder constructed from structural hollow sections is almost always welded, with one element welded directly to the next, e.g. bracing to chord. This means that the sizing of the members has a direct effect on the actual resistance of the joint. It is imperative that you select member sizes and thicknesses so the resistance of the joint is not compromised. This is explained further in section 4.

The assumption of centre line nodding and pinned connections obtains a good approximation of the member's axial forces. However, due to the inherent stiffness of the joints, bending moments will be introduced into chord members of a real girder with continuous chords and welded connections. Sometimes, it may be necessary to depart from the ideal nodding conditions in order to achieve the desired gap or overlap conditions between the bracings.

To derive the joint design recommendations, many of the tests on welded joints incorporated nodding eccentricities as large as $\pm d_0/2$ or $\pm h_0/2$ (**Figure 7**).

Figure 6:

Noding joints

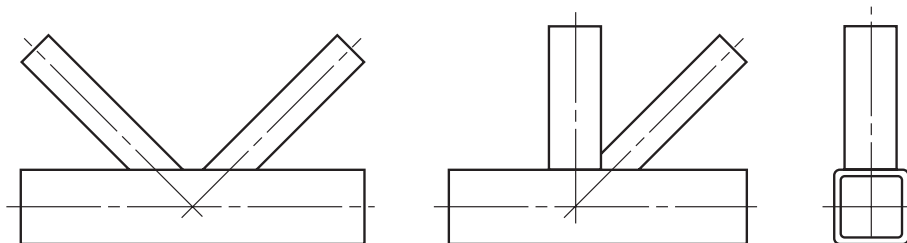

In the design of joint resistance, chord and brace design, you may neglect the effects of secondary moments due to joint rotational stiffness, in the following circumstances:

- a) The joints are within the validity limits given in section 5,
- b) For building structures, the ratio of system length to section depth (in the plane of the lattice girder) is not less than 6.
- c) The joint eccentricity is within the limits specified below

Moments due to transverse loads applied between panel points (nodes) should be taken into account in the design of members, and joints where it affects the chord stress factors k_m , k_n and k_p .

Moments due to eccentricity can be neglected providing the eccentricity is within the limits:

$$-0.55 (d_0 \text{ or } h_0) \leq e \leq +0.25 (d_0 \text{ or } h_0)$$

For these additional moments, if the eccentricity is within these limits, you should still check the member design for compression chords. Moments produced should be divided into the compression chord each side of the joint dependant of their relative stiffness coefficients I/L about the relevant axis (where L is the system length of the member measured between panel points or lateral supports, depending upon the axis in consideration. I is the Moment of Inertia about a relevant axis).

Outside these eccentricity limits, moments due to joint eccentricity should be considered in the design of the joints, chord and bracings not considered pinned. The resulting moments being divided between all the joint members, in relation to their relative stiffness coefficients I/L about the relevant axis.

When calculating chord end stress factors k_m , k_n and k_p , you need to take into account additional chord stresses due to secondary moments generated by joint eccentricity.

Figure 7:

Definition of joint eccentricity

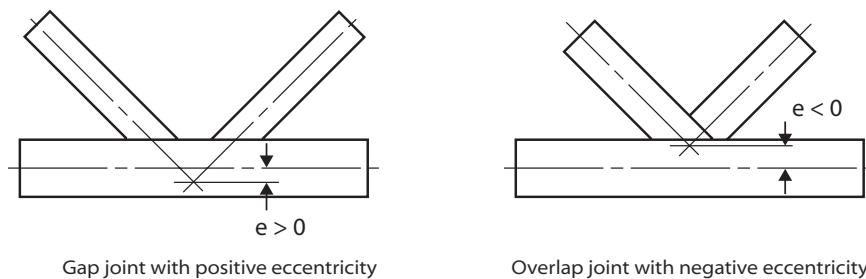

3.2 Welding

Only the main points regarding welding of structural hollow section lattice type joints are given here. More detailed information on welding methods, end preparation, weld strengths, weld types, weld design, etc. should be discussed with the fabricator.

When a bracing member is under load, a non-uniform stress distribution is present in the bracing close to the joint, see **figure 8**. Therefore, to allow for this non-uniformity of stress, the welds connecting the bracing to the chord must be designed to have sufficient resistance.

Normally, the weld should be around the whole perimeter of the bracing using butt-weld, fillet-weld or a combination of the two. However, in partially overlapped bracing joints the hidden part of the joint need not be welded, if the bracing force components perpendicular to the chord axis do not differ by more than 20%. In the case of 100% overlap joints, the toe of the overlapped bracing must be welded to the chord. To achieve this, the overlap may be increased to a maximum of 110% to allow the toe of the overlapped bracing to be satisfactorily welded to the chord.

Figure 8:

Typical localised stress distribution at a joint

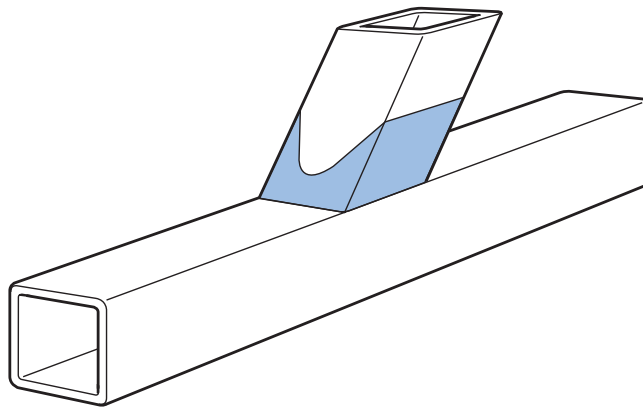

3.2.1 Prequalified Weld Throat Thickness, a (figure 9)

For bracing members in a lattice construction, the design resistance of a fillet-weld should not normally be less than the design resistance of the member. This is satisfied if the throat size (a) is at least equal to or larger than the values shown in **figure 9**, provided you use electrodes with an equivalent strength grade to the steel (both yield and tensile strength), see also **figure 10**.

You may waive the requirements of **figure 9** where a smaller weld size can be justified with regard to both resistance and deformational/rotational resistance, taking account of the possibility that only part of the weld's length may be effective.

Or from the simplified method for design of fillet weld EN 1993:1-8 clause 4.5.3.3

$$F_{w,Ed} < F_{w,Rd}$$

Where

$F_{w,Ed}$ is the design value of the weld force per unit length

$F_{w,Rd}$ is the design weld resistance per unit length

For a more efficient weld use the directional method from EN 1993:1-8 clause 4.5.3.2

Figure 9: Pre-qualified Weld Throat Thickness

Structural hollow section material	Minimum throat size, a (mm)
Celsius® 355 and Hybox® 355	1.11 x t _i *

* see **figure 10** for bracing thickness, t_i and throat thickness, a

Figure 10:

Weld throat thickness

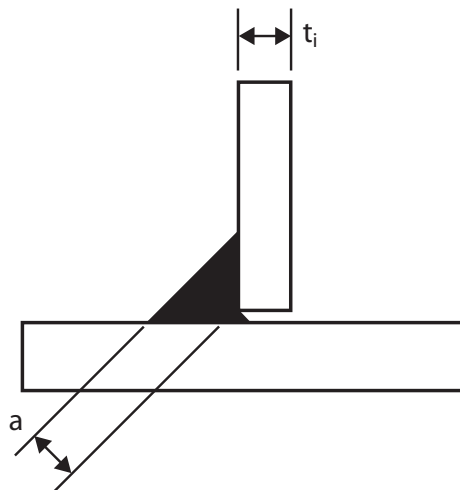

The weld at the toe of an inclined bracing is very important, see **figure 11**. The toe area tends to be more highly stressed than the remainder of its periphery because of the non-uniform stress distribution around the bracing at the chord face. It is recommended that the toe of the bracing is bevelled and if the bracing angle, θ , is less than 60° , a butt-weld should always be used. If the angle, θ , is 60° or greater, then the weld type used for the remainder of the weld should be used, i.e. either a fillet or a butt weld.

Figure 11:

Weld detail at bracing toe

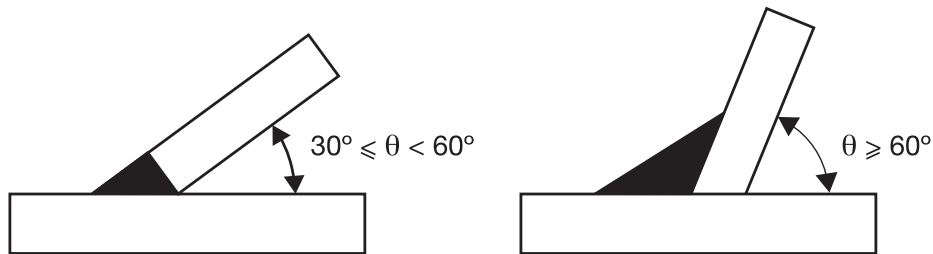

3.2.2 Welding in the corner regions of rectangular and square structural hollow sections.

Celsius® 355 has no issues when welding in the corner region. This is because it is manufactured at normalising temperature using the hot forming process. However, cold-formed structural hollow sections may not comply with EN 1993-1-8: clause 4.14, restricting welding within $5t$ of the corner region unless:

- The cold formed zones are normalized after cold forming but before welding, or
- If the internal corner radius (r) is satisfied depending on the relevant thickness from table 4.2 in EN1993-1-8.

3.3 Fabrication

In a lattice type construction, the largest fabrication cost is the end preparation and welding of the bracings, and the smallest is the chords. For example, in a typical 30m span girder, the chords would probably be made from three lengths of material with straight cuts and two end-to-end butt welds. The bracings would be around twenty-five, all requiring bevel cutting or profiling (if using a circular chord), and welding at each end.

As a general rule the number of bracing members should be as small as possible. The best way to achieve this is using K-type bracings, rather than N-type bracings. Hollow sections are much more efficient in compression than open sections, angles or channels, meaning compression bracings do not need to be as short as possible. This makes the K-type bracing layout much more efficient.

In circular chords, the ends of each bracing in a girder has to be profile-shaped to fit around the curvature of the chord member (see **figure 12**), unless the bracing is very much smaller than the chord. Also, for overlap joints with circular bracings and chords, the overlapping bracing has to be profile shaped to fit to both chord and the overlapped bracing.

Unless the bracings partially overlap, only a single straight cut is required at the ends of the bracings for joints with rectangular chords and either rectangular or circular bracings.

As well as the end preparation of the bracings, the ease with which the members of a girder, or other construction, can be put into position and welded, will affect the overall costs. Generally it is much easier and cheaper to assemble and weld a girder with a gap between the bracings, than one with the bracings overlapping. Gap joints have a much slacker tolerance on 'fit up' and the actual location of the panel points can easily be maintained by slight adjustments as each bracing is fitted. Accumulated errors can occur at panel point locations, where joints have overlapping bracings, especially partial overlapping ones.

More detailed information on fabrication, assembly and erection is given in CIDECT Design Guide for Fabrication, Assembly and Erection of Hollow Section Structures [15].

Figure 12:

Connections to a circular chord

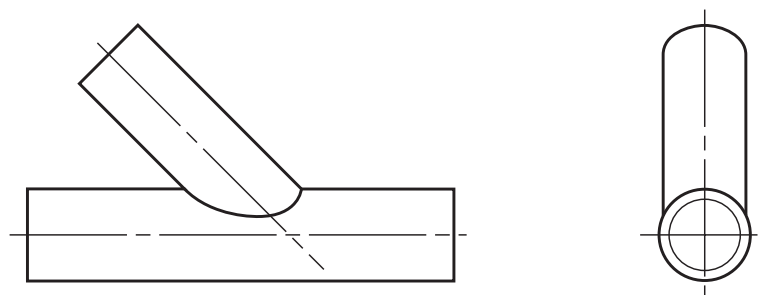

4 PARAMETERS AFFECTING JOINT RESISTANCE

4.1 General

The various geometric parameters of the joint have an effect on its resistance. This is dependant on the:

- joint type (single bracing, two bracings with a gap or an overlap) and,
- type of forces on the joint (tension, compression, moment).

Depending on these various conditions, a number of different failure modes are possible (see section 4.2).

Design is always a compromise between various conflicting requirements. The following highlights some of the points that need to be considered in an efficient design.

1) The joint

- a) The joint resistance will always be higher if the thinner member sits on and is welded to the thicker member, rather than the other way around.
- b) Joints with overlapping bracings will generally have a higher resistance than joints with a gap between the bracings.
- c) The joint resistance, for all joint and load types (except fully overlapped joints), will be increased if small thick chords rather than larger and thinner chords are used.
- d) Joints with a gap between the bracings have a higher resistance if the bracing to chord width ratio is as high as possible. This means large thin bracings and small thick chords.
- e) Joints with partially overlapping bracings have a higher resistance if both the chord and the overlapped bracing are as small and thick as possible.
- f) Joints with fully overlapping bracings have a higher resistance if the overlapped bracing is as small and thick as possible. In this case, the chord has no effect on the joint resistance.
- g) On a size for size basis, joints with circular chords will have a higher resistance than joints with rectangular chords.

2) The overall girder requirements



- a) The overall girder behaviour, e.g. lateral stability, is increased if the chord members are large and thin. This also increases the compression chord strut resistance, due to its larger radius of gyration.
- b) Consideration must also be given to the fabrication costs as discussed in section 3.3.

4.2 Joint failure modes

Joints have a number of different failure modes depending on the joint type, the geometric parameters of the joint and the type of loading. These various types of failure are described in **figures 13 to 19**.

The number of failure modes is limited **figures 13 to 19** if you adhere to the relevant geometric validity limits given in section 5. However, if this is not the case then other failure modes may become critical (which are not covered in this technical brochure).

Joint failure modes

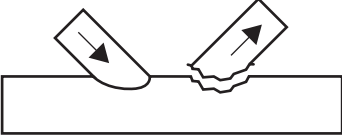
Failure	Description	Diagram
<p>Chord face failure (otherwise known as deformation, yielding or plastic failure (plastification))</p>	<p>This is the most common failure mode for joints with a single bracing, and for K- and N-joints with a gap between the bracings if the bracing to chord width ratio (β) is less than 0.85.</p>	 <p>Figure 13: Chord face failure</p>
<p>Chord side wall failure (or chord web failure)</p>	<p>This is the yielding, crushing or instability (cripling or buckling) of the chord sidewall or web under the compression brace member. Also includes sidewall yielding if the bracing is in tension. Usually only occurs when the bracing to chord width ratio (β) ratio is greater than about 0.85, especially for joints with a single bracing.</p>	 <p>Figure 14: Chord side wall failure</p>
<p>Chord shear</p>	<p>Is found typically in the gap of a K-joint. The opposite vertical bracing force causes the chord to shear. It does not often become critical, but can if you use rectangular chords with the width (b_0) greater than the depth (h_0). If the validity limits given in section 5 are met then chord shear does not occur with circular chords.</p>	 <p>Figure 15: Chord shear</p>
<p>Chord punching shear</p>	<p>Can be caused by a crack initiation in the chord face leading to rupture failure of the chord. It is not usually critical, but can occur when the chord width to thickness ratio (2γ) is small.</p>	 <p>Figure 16: Chord punching shear</p>

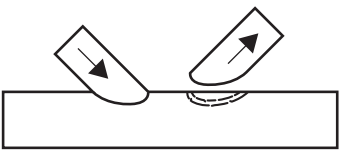
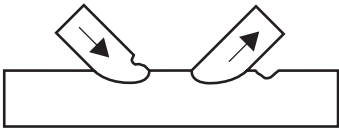
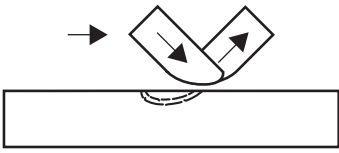
Failure	Description	Diagram
Bracing effective width	<p>This is non-uniform stress distribution in the brace causing a reduced effective brace width. This reduces the effective area carrying the bracing force. It is mainly associated with rectangular chord gap joints with large β ratios and thin chords. It is also the predominant failure mode for rectangular chord joints with overlapping rectangular bracings.</p>	 <p>The diagram shows a horizontal rectangular chord with two overlapping rectangular bracings attached to its top surface. Arrows on the bracings indicate they are under tension. The failure mode is shown as a localized indentation or crushing of the chord's top surface directly under the overlapping region of the two bracings.</p> <p>Figure 17: Bracing effective width</p>
Chord or bracing localised buckling	<p>Due to the non-uniform stress distribution at the joint, reducing the effective area carrying the bracing forces. This failure mode will not occur if the validity ranges given in section 5 are met.</p>	 <p>The diagram shows a horizontal rectangular chord with two overlapping rectangular bracings attached to its top surface. Arrows on the bracings indicate they are under tension. The failure mode is shown as a localized buckling or crushing of the chord's top surface directly under the overlapping region of the two bracings.</p> <p>Figure 18: Localised buckling of the chord or bracings</p>
Shear of overlapping bracings	<p>Due to the bracing's horizontal force causing shearing at the chord face. This failure mode becomes critical for large overlaps, over 80% or 60%, depending if the hidden toe of the overlapped bracing is welded to the chord.</p>	 <p>The diagram shows a horizontal rectangular chord with two overlapping rectangular bracings attached to its top surface. Arrows on the bracings indicate they are under tension. A horizontal arrow on the left indicates the direction of the bracing force. The failure mode is shown as a shear failure at the chord face where the overlapped bracing is welded to the chord.</p> <p>Figure 19: Shear of overlapping bracings</p>

4.3 Parameter Effects

4.3.1 Joints with a single bracing

The statements given in **figure 20** will only be true provided that the joint resistance does not exceed the resistance of the members. In all cases the resistance is defined as a force along the axis of the bracing.

Figure 20:

Effect of parameter changes on the resistance of T-, Y- and X-joints

Joint parameter	Parameter value	Effect on joint resistance	
Chord width to thickness ratio	$\frac{d_0}{t_0}$ or $\frac{b_0}{t_0}$	Reduced	Increased
Bracing to chord width ratio	$\frac{d_1}{d_0}$ or $\frac{b_1}{b_0}$	Increased	Increased*
Bracing angle	θ_1	Reduced	Increased
Bracing to chord strength factor	$\frac{f_{y1} t_1}{f_{y0} t_0}$	Reduced	Increased

* provided that rectangular chord side wall buckling does not become critical, when $\beta > 0.85$

4.3.2 Joints with a gap between bracings

The statements given in **figure 21** will only be true provided that the joint resistance does not exceed the resistance of the members. In all cases the resistance is defined as a force along the axis of the bracing.

Figure 21:

Effect of parameter changes on the resistance of K- or N-joints with gap

Joint parameter	Parameter value	Effect on joint resistance	
Chord width to thickness ratio	$\frac{d_0}{t_0}$ or $\frac{b_0}{t_0}$	Reduced	Increased
Bracing to chord width ratio	$\frac{d_i}{d_0}$ or $\frac{b_i}{b_0}$	Increased	Increased*
Bracing angle	θ_1	Reduced	Increased
Bracing to chord strength factor	$\frac{f_{yi} t_i}{f_{y0} t_0}$	Reduced	Increased
Gap between bracings	g	Reduced	Increased**

* provided that rectangular chord side wall buckling does not become critical, when $\beta > 0.85$

** only true for circular chord joints

4.3.3 Joints with overlapped bracings

The statements given in **figure 22** will only be true provided that the joint resistance does not exceed the resistance of the members. In all cases the resistance is defined as a force along the axis of the bracing.

Figure 22:

Effect of parameter changes on the resistance of K- or N-joints with overlap

Joint parameter		Parameter value	Effect on resistance CHS	Effect on resistance RHS
Chord width to thickness ratio	$\frac{d_0}{t_0}$ or $\frac{b_0}{t_0}$	Reduced	Increased	Increased
Overlapped bracing width to thickness ratio	$\frac{b_j}{t_j}$	Reduced	N/A	Increased
Bracing to chord width ratio	$\frac{d_i}{d_0}$ or $\frac{b_i}{b_0}$	Increased	Increased	Increased
Bracing angle	θ_i or θ_j	Reduced	Increased	N/A
Overlapped bracing to chord strength factor	$\frac{f_{yj} t_j}{f_{y0} t_0}$	Reduced	N/A	Increased
Bracing to bracing strength factor	$\frac{f_{yi} t_i}{f_{yj} t_j}$	Reduced	N/A	Increased
Overlap of bracings	λ_{ov}	Increased	Increased	Increased

4.4 Joint reinforcement

Appropriate reinforcement may be used to increase the design resistance if required. Adding reinforcement to a joint should only be carried out after careful consideration, when you cannot change either the joint geometry or the member sizes. From a fabrication point of view it is relatively expensive and can be aesthetically obtrusive.

The type of reinforcement required depends upon the critical failure mode causing the lowest resistance. Methods for reinforcing both circular and rectangular chord joints are given in **figures 23–25**. Alternatively, the joint can be reinforced by replacing the chord with a thicker section with minimum length l_p .

The required minimum reinforcement thickness, t_p , is calculated by rearranging the relevant formula in section 5. In the case of circular chord saddle and rectangular chord face reinforcement, only t_p , and not $t_0 + t_p$ combined should be used to determine the reinforced joint resistance.

where t_p = reinforcement thickness
and t_0 = chord thickness

For rectangular chord side wall reinforcement, the combined thickness may be used for the shear resistance. However, for chord side wall buckling, the chord side wall and the reinforcement should be considered as two separate plates and their resistance added together.

The reinforcement plate should be at least the same steel grade as the chord material. For circular saddle and rectangular chord face reinforcement, the plate should have good through thickness properties with no laminations. The weld used to connect the reinforcement to the hollow section chord member should be made around the total periphery of the plate.

Special care and precautions should be taken if the structure is to be galvanised and reinforcing plates are fully welded. These details should be discussed with the galvaniser at the earliest opportunity.

4.4.1 Reinforcement of circular chord joints

External reinforcement can be by saddle or collar, where either a curved plate or part of a thicker circular hollow section is used respectively. The size and type of reinforcement is shown in **figure 23**. The dimensions of the reinforcement should be as shown below.

$$w_p = \pi d_0 / 2$$

for K- or N-gap joints: $l_p \geq 1.5 (d_1 / \sin\theta_1 + g + d_2 / \sin\theta_2)$

for T-, X- or Y-joints: $l_p \geq 1.5 d_1 / \sin\theta_1$

for transverse gusset plate joints: $l_p \geq 4 d_0 + t_1$

for longitudinal gusset plate joints: $l_p \geq 4 h_1 + t_1$

t_p = required reinforcement plate thickness

Figure 23:

Circular chord reinforcement

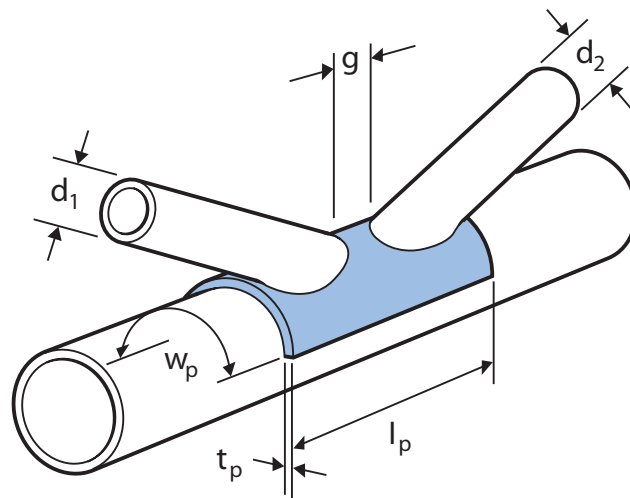

4.4.2 Reinforcement of rectangular chord gap K-, T-, Y- and X-joints

Depending upon the critical failure mode, a gap joint with rectangular chords can be reinforced in several ways.

- Chord face deformation, chord punching shear or bracing effective width – reinforce the face of the chord where the bracings will be attached (see **figure 24**).
- Chord side wall buckling or chord shear – plates should be welded to the sidewalls of the chord (see **figure 25**).

The required dimensions of the reinforcing plates are shown below.

Face Plate Reinforcement

t_p = required reinforcement plate thickness

For T-, Y-, X-joints: ($b_1/b_p \leq 0.85$)

$$l_p \geq \frac{h_1}{\sin\theta_1} + \sqrt{b_p (b_p - b_1)}$$

$$b_p \geq b_0 - 2t_0$$

$$t_p \geq 2t_1$$

For Tension:

$$N_{1,Rd} = \frac{f_{yp} t_p^2}{(1-b_1/b_p) \sin\theta_1} \left[\frac{2h_1/b_p}{\sin\theta_1} + 4 \sqrt{1-b_1/b_p} \right] / \gamma_{M5}$$

For compression:

Take $N_{1,Rd}$ as the value of $N_{1,Rd}$ for a T-, Y- or X-joint from section 5.3.3, but with $k_n=1.0$ and t_0 replaced by t_p for chord face failure, brace failure and punching shear only.

Figure 24:

Rectangular chord face reinforcement

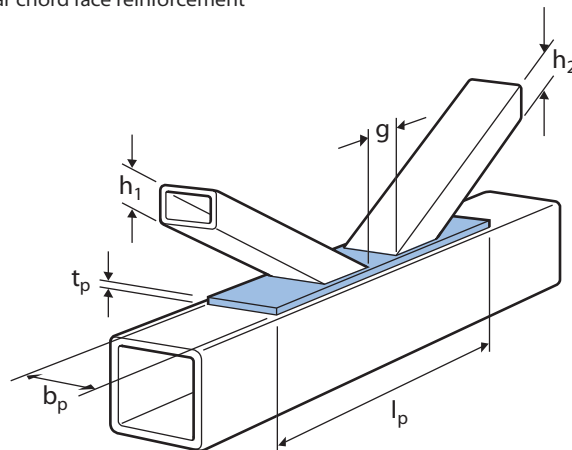

For K & N Joints:

$$l_p \geq 1.5 \left[\frac{h_1}{\sin\theta_1} + g + \frac{h_2}{\sin\theta_2} \right]$$

$$b_p \geq b_0 - 2t_0$$

$$t_p \geq 2t_1 \text{ and } 2t_2$$

Take $N_{i,Rd}$ as the value of $N_{i,Rd}$ for a K- or N-joint from section 5.3.3, but with t_0 replaced by t_p for chord face failure, brace failure and punching shear only.

Side Plate Reinforcement

t_p = required reinforcement plate thickness

For K- or N-gap joints:

$$l_p \geq 1.5 (h_1/\sin\theta_1 + g + h_2 / \sin\theta_2)$$

$$b_p \geq h_0 - 2t_0$$

Take $N_{i,Rd}$ as the value of $N_{i,Rd}$ for a K- or N- joint from section 5.3.3, but with t_0 replaced by (t_0+t_p) for chord shear only.

For T-, X-, Y-joints:

$$l_p \geq 1.5h_1 / \sin\theta_1$$

$$b_p \geq h_0 - 2t_0$$

Take $N_{1,Rd}$ as the value of $N_{1,Rd}$ for T-, Y- or X-joint from section 5.3.3, but with t_0 replaced by (t_0+t_p) for chord side wall buckling failure and chord side wall shear only.

Figure 25:

Rectangular chord side wall reinforcement

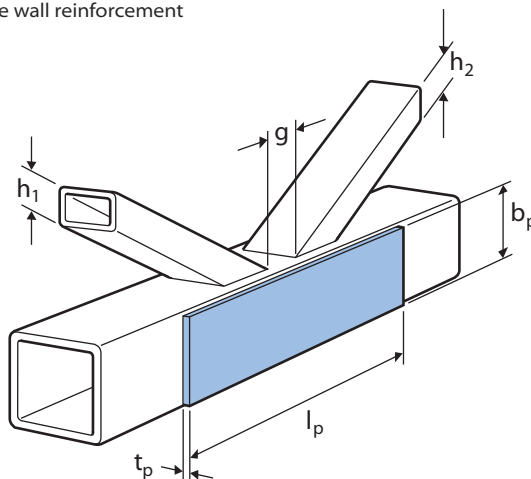

4.4.3 Reinforcement of rectangular chord overlap joints

Using a transverse plate (**figure 26**) can reinforce an overlap joint with rectangular chords. The plate width, b_p , should generally be wider than the bracings, to allow a fillet weld with a throat thickness equal to the bracing thickness.

$$b_p \geq b_1 + 3.1t_1$$

$$t_p \geq 2t_1 \text{ and } t_p \geq 2t_2$$

Take $N_{i,Rd}$ as the value of $N_{i,Rd}$ for a K- or N-overlap joint from section 5.3.3 with $\lambda_{ov} < 80\%$, but with b_j , t_j and f_{yj} replaced by b_p , t_p and f_{yp} in the expression for $b_{e,ov}$ given in section 5.3.2.2.

Figure 26:

Rectangular chord transverse plate reinforcement

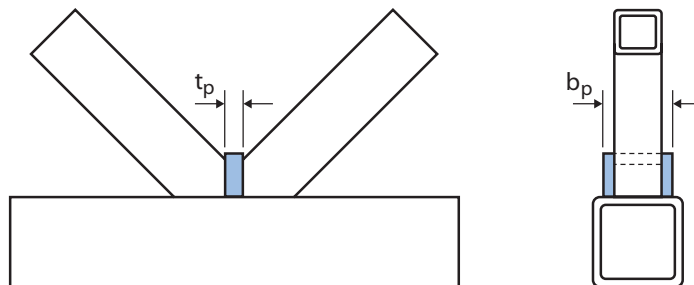

5 JOINT DESIGN FORMULAE

When more than one failure mode is given, the value of the lowest resulting resistance should be used. In all cases any applied factored moment should be taken as that acting at the chord face and not that at the chord centre line.

5.1 Circular hollow section chord joints

All dimensions used in the design formulae and validity limits are nominal.

5.1.1 Circular chord joint validity limits

Joints with circular chords should be within the validity range of **figure 27**;

Figure 27:

Circular hollow section joint validity limits

Joint type	Bracing type	Chord $\frac{d_0}{t_0}$	Brace $\frac{d_i}{t_i}$	Brace/chord	Eccentricity	Gap or overlap	Brace angle
T-, K- and N-joints	Circular	≥ 10 ≤ 50 & class 1 or 2 when in compression	≤ 50 & class 1 or 2 when in compression	0.2 $\leq d_i/d_0 \leq$ 1.0	$-0.55 d_0$ $\leq e \leq$ $+0.25 d_0$	$g \geq t_1+t_2$ but $\leq 12t_0^*$ $25\% \leq \lambda_{ov}$	30° $\leq \theta_1 \leq$ 90°
X-joints		≥ 10 ≤ 40 & class 1 or 2 when in compression			-	-	
T-joints	Transverse plate	≥ 10 ≤ 50 & class 1 or 2 when in compression	-	0.4 $\leq b_1/d_0 \leq$ 1.0	-	-	$\theta_1 \approx 90^\circ$
X-joints		≥ 10 ≤ 40 & class 1 or 2 when in compression					
T-joints	Longitudinal plate	≥ 10 ≤ 50 & class 1 or 2 when in compression	-	$h_1/d_0 \leq 4.0^{**}$	-	-	
X-joints		≥ 10 ≤ 40 & class 1 or 2 when in compression					
T-joints	Rectangular and I- or H- section	≥ 10 ≤ 50 & class 1 or 2 when in compression	-	$b_1/d_0 \geq 0.4$ $h_1/d_0 \leq 4.0^{**}$	-	-	30° $\leq \theta_1 \leq$ 90°
X-joints		≥ 10 ≤ 40 & class 1 or 2 when in compression					

* when $g > 12t_0$ the joint will act more like 2 separate T-joints. If above this limit, it is recommended to additionally check as 2 separate T-joints and use lowest resistance.

** can be physically >4 , but for calculation purposes should not be taken as >4

Section classification is for compression

For large circular hollow sections the d_0/t_0 validity limit can easily be exceeded, section 2.1.1 explains how the design yield can be reduced to still enable application of the formulae.

5.1.2 Circular chord joint factors

The following factors are used during the calculation of circular chord joint resistances:

5.1.2.1 Chord stress factor, k_p – see figure 28

For $n_p > 0$ (compression): $k_p = 1 - 0.3 n_p (1 + n_p)$ but $k_p \leq 1.0$

For $n_p \leq 0$ (tension): $k_p = 1.0$

where: $n_p = (\sigma_{p,Ed} / f_{y0})$

n_p is the least compressive applied factored stress ratio in the chord, adjacent to the joint and is negative for tension.

$$\sigma_{p,Ed} = \frac{N_{p,Ed}}{A_0} + \frac{|M_{ip,0,Ed}|}{W_{el,ip,0}} + \frac{|M_{op,0,Ed}|}{W_{el,op,0}}$$

$\sigma_{p,Ed}$ is the least compressive applied factored stress in the chord, adjacent to the joint due to axial forces and moments and is negative for tension.

Figure 28:

Circular joint

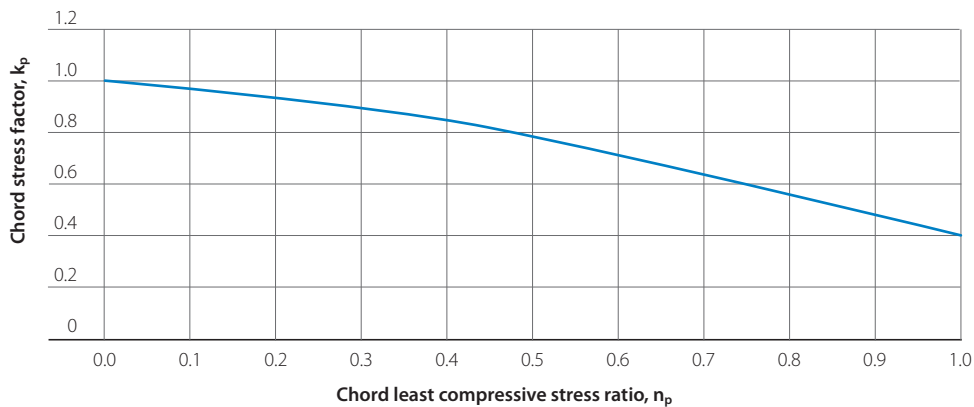

5.1.2.2 Gap/lap factor, k_g – see figure 29

$$k_g = \gamma^{0.2} \left[1 + \frac{0.024 \gamma^{1.2}}{1 + \exp(0.5g/t_0 - 1.33)} \right]$$

Gap (g) is positive for a gap joint and negative for an overlap joint

Figure 29:

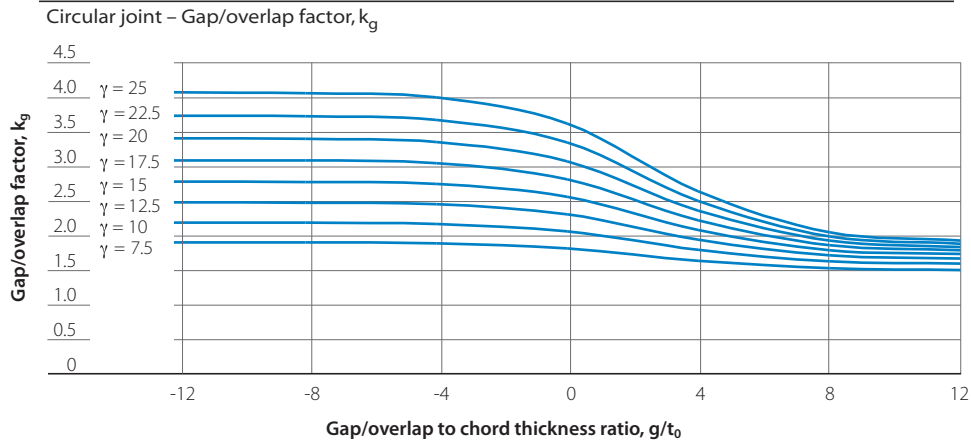

5.1.2.3 Bracing effective widths, $d_{eff,i}$ and $d_{eff,j}$

Brace effective width (overlapping brace): $d_{eff,i} = \frac{12t_0}{d_0} \times \frac{f_{y0} t_0}{f_{yi} t_i} d_i$ but $d_{eff,i} \leq d_i$

Brace effective width (overlapped brace): $d_{eff,j} = \frac{12t_0}{d_0} \times \frac{f_{y0} t_0}{f_{yj} t_j} d_j$ but $d_{eff,j} \leq d_j$

(Suffix 'j' indicates the overlapped bracing)

5.1.3 Circular chords and circular bracings with axial forces

T- and Y-joints

Chord face failure: $N_{1,Rd} = \frac{\gamma^{0.2} k_p f_{y0} t_0^2}{\sin\theta_1} (2.8 + 14.2\beta^2) / \gamma_{M5}$

X-joints

Chord face failure: $N_{1,Rd} = \frac{k_p f_{y0} t_0^2}{\sin\theta_1} \frac{5.2}{(1 - 0.81\beta)} / \gamma_{M5}$

For X-joints with $\cos\theta_1 > \beta$ also check chord shear between the braces: check $V_{pl,0,Rd} \geq V_{0,Ed}$

$$V_{pl,0,Rd} = \frac{A_{v,0} (f_{y0} / \sqrt{3})}{\gamma_{M0}}$$

K- and N-joints

Compression brace (brace 1):

Chord face failure: $N_{1,Rd} = \frac{k_g k_p f_{y0} t_0^2}{\sin\theta_1} (1.8 + 10.2 \frac{d_1}{d_0}) / \gamma_{M5}$

Tension brace (brace 2):

Chord face failure: $N_{2,Rd} = \frac{\sin\theta_1}{\sin\theta_2} N_{1,Rd}$

For all these joint types, except those with overlapping bracings, the joint must also be checked for chord punching shear failure when $d_i \leq d_0 - 2 t_0$ (for each brace):

$$\text{Chord punching shear: } N_{i,Rd} = \frac{f_{y0}}{\sqrt{3}} t_0 \pi d_i \frac{1 + \sin \theta_i}{2 \sin^2 \theta_i} / \gamma_{M5}$$

Local shear of circular overlapping bracings:

when:

60% < λ_{ov} < 100% and overlapped brace hidden seam is not welded

80% < λ_{ov} < 100% and overlapped brace hidden seam is welded

$$N_i \cos \theta_i + N_j \cos \theta_j \leq \frac{\pi}{4} \left[\frac{f_{ui}}{\sqrt{3}} \times \frac{\left[\left(\frac{100 - \lambda_{ov}}{100} \right) 2d_i + d_{eff,i} \right] t_i}{\sin \theta_i} + \frac{f_{uj}}{\sqrt{3}} \times \frac{(2d_j + c_s d_{eff,j}) t_j}{\sin \theta_j} \right] / \gamma_{M5}$$

when $\lambda_{ov} \geq 100\%$:

$$N_i \cos \theta_i + N_j \cos \theta_j \leq \frac{f_{uj}}{\sqrt{3}} \times \frac{\pi}{4} \times \frac{(3d_j + d_{eff,j}) t_j}{\sin \theta_j} / \gamma_{M5}$$

where: i = overlapping brace and j = overlapped brace

$c_s = 1$ when hidden toe is not welded

$c_s = 2$ when hidden toe is welded

for $d_{eff,i}$ and $d_{eff,j}$ see section 5.1.2.3

5.1.4 Circular chords and circular bracings with moments in plane (M_{ip})

T-, Y-, X-joints

$$\text{Chord face failure: } M_{ip,1,Rd} = 4.85 \frac{f_{y0} t_0^2 d_1}{\sin \theta_1} \sqrt{\gamma} \beta k_p / \gamma_{M5}$$

for k_p see section 5.1.2.1

The joint must also be checked for chord punching shear failure when $d_1 \leq d_0 - 2 t_0$:

$$\text{Chord punching shear: } M_{ip,1,Rd} = \frac{f_{y0} t_0^2 d_1^2}{\sqrt{3}} \frac{1 + 3 \sin \theta_1}{4 \sin^2 \theta_1} / \gamma_{M5}$$

5.1.5 Circular chords and circular bracings with moments out of plane (M_{op})

T-, Y-, X-, K- and N-joints with gap

$$\text{Chord face deformation: } M_{op,i,Rd} = \frac{f_{y0} t_0^2 d_i}{\sin \theta_i} \frac{2.7}{1-0.81\beta} k_p / \gamma_{M5}$$

for k_p see section 5.1.2.1

The joint must also be checked for chord punching shear failure when $d_i \leq d_0 - 2 t_0$ (for each brace on K- and N-joints);

$$\text{Chord punching shear: } M_{op,i,Rd} = \frac{f_{y0} t_0 d_i^2}{\sqrt{3}} \frac{3 + \sin \theta_i}{4 \sin^2 \theta_i} / \gamma_{M5}$$

5.1.6 Circular chords with transverse gusset plates

T-joints axial force chord face failure

$$\text{Chord face failure: } N_{1,Rd} = k_p f_{y0} t_0^2 (4 + 20\beta^2) / \gamma_{M5}$$

X-joints axial force chord face failure

$$\text{Chord face failure: } N_{1,Rd} = \frac{5k_p f_{y0} t_0^2}{1-0.81\beta} / \gamma_{M5}$$

for k_p see section 5.1.2.1

T- and X-joints in-plane moment chord face failure

$$\text{Chord face failure: } M_{ip,1,Rd} = t_1 N_{1,Rd}$$

Figure 30:

Circular chord with transverse gusset plate

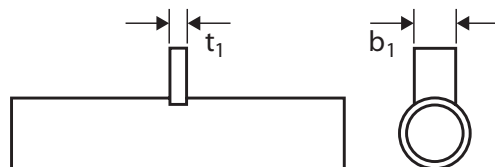

T- and X-joints out-of-plane moment chord face failure

Chord face failure: $M_{op,1,Rd} = 0.5 b_1 N_{1,Rd}$

T- and X-joint chord punching shear

In all cases the following check must be made to ensure that any factored applied axial forces and moments do not exceed the chord punching shear resistance.

Chord punching shear check:
$$\left[\frac{|N_{1,Ed}|}{A_1} + \frac{|M_{ip,1,Ed}|}{W_{el,ip,1}} + \frac{|M_{op,1,Ed}|}{W_{el,op,1}} \right] t_1 \leq \frac{2t_0 f_{y0}}{\sqrt{3}} / \gamma_{M5}$$

5.1.7 Circular chords with longitudinal gusset plates

T- and X-joints axial force chord face failure

Chord face failure: $N_{1,Rd} = 5k_p f_{y0} t_0^2 (1 + 0.25\eta) / \gamma_{M5}$

for k_p see section 5.1.2.1

T- and X-joints in-plane moment chord face failure

Chord face failure: $M_{ip,1,Rd} = h_1 N_{1,Rd}$

T- and X-joints out-of-plane moment chord face failure

Chord face failure: $M_{op,1,Rd} = 0.5 t_1 N_{1,Rd}$

Figure 31:

Circular chord with longitudinal gusset plate

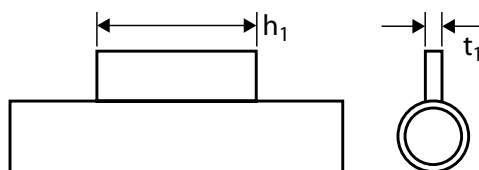

T- and X-joint chord punching shear

In all cases the following check must be made to ensure that any factored applied axial forces and moments do not exceed the chord punching shear resistance.

$$\text{Chord punching shear check: } \left[\frac{|N_{1,Ed}|}{A_1} + \frac{|M_{ip,1,Ed}|}{W_{el,ip,1}} + \frac{|M_{op,1,Ed}|}{W_{el,op,1}} \right] t_1 \leq \frac{2t_0 f_{y0}}{\sqrt{3}} / \gamma_{M5}$$

5.1.8 Circular chords and I-, H- or rectangular bracings

T-joints chord face failure

$$\text{Chord face failure: } N_{1,Rd} = k_p f_{y0} t_0^2 (4 + 20\beta^2)(1+0.25\eta) / \gamma_{M5}$$

$$\text{Chord face failure: } M_{ip,1,Rd} = h_1 N_{1,Rd} / (1 + 0.25\eta) \quad \text{:for I- and H- bracings}$$

$$\text{Chord face failure: } M_{ip,1,Rd} = h_1 N_{1,Rd} \quad \text{:for rectangular bracings}$$

$$\text{Chord face failure: } M_{op,1,Rd} = 0.5 b_1 N_{1,Rd}$$

X-joints chord face failure

$$\text{Chord face failure: } N_{1,Rd} = \frac{5k_p f_{y0} t_0^2}{1-0.81\beta} (1 + 0.25\eta) / \gamma_{M5}$$

$$\text{Chord face failure: } M_{ip,1,Rd} = h_1 N_{1,Rd} / (1 + 0.25\eta) \quad \text{:for I- and H- bracings}$$

$$\text{Chord face failure: } M_{ip,1,Rd} = h_1 N_{1,Rd} \quad \text{:for rectangular bracings}$$

$$\text{Chord face failure: } M_{op,1,Rd} = 0.5 b_1 N_{1,Rd}$$

for k_p see section 5.1.2.1

Figure 32:

Circular chord with I-, H- or rectangular bracings

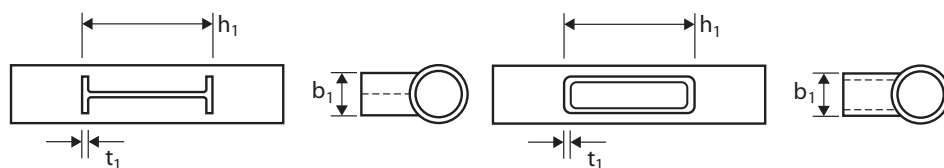

T- and X-joint chord punching shear

In all cases the following check must be made to ensure that any factored applied axial forces and moments do not exceed the chord punching shear resistance.

Punching shear check for I- and H- bracings with $\eta \leq 2$ (for axial compression and out-of-plane bending) and rectangular sections;

$$\left[\frac{|N_{1,Ed}|}{A_1} + \frac{|M_{ip,1,Ed}|}{W_{el,ip,1}} + \frac{|M_{op,1,Ed}|}{W_{el,op,1}} \right] t_1 \leq \frac{t_0 f_{y0}}{\sqrt{3}} / \gamma_{M5}$$

all other cases:

$$\left[\frac{|N_{1,Ed}|}{A_1} + \frac{|M_{ip,1,Ed}|}{W_{el,ip,1}} + \frac{|M_{op,1,Ed}|}{W_{el,op,1}} \right] t_1 \leq \frac{2t_0 f_{y0}}{\sqrt{3}} / \gamma_{M5}$$

where t_1 is the flange or wall thickness of the transverse I-, H-, or rectangular section

5.2 Knee joints in circular hollow sections

All dimensions used in the design formulae and validity limits are nominal.

Although rectangular welded knee joints are included in EN 1993-1-8:2005, there is no information on circular welded knee joints. The following is based on a paper entitled 'The static design of stiffened and unstiffened CHS L-joints' [16]. Due to its profile, circular knee joints suffer lower moment resistance than equivalent rectangular knee joints.

Figure 33:

Circular hollow section knee joint validity limits

Knee Joint type	d_0/t_0	t_p	Brace angle
Un-reinforced	≥ 10 & class 1	-	$90^\circ \leq \theta_0 \leq 180^\circ$
Reinforced	≥ 10 & class 1 or 2	$2.0 t_0 \leq t_p$ but $\geq 10\text{mm}$	

5.2.1 Circular welded knee joint validity limits

Knee joints with circular hollow sections chords should be within the validity range of **figure 33**;

Different diameter circular hollow sections should not be used. If different thickness circular hollow sections are to be welded then the thinner tube thickness should be used in the formulae.

Figure 34:

Un-reinforced circular knee joint

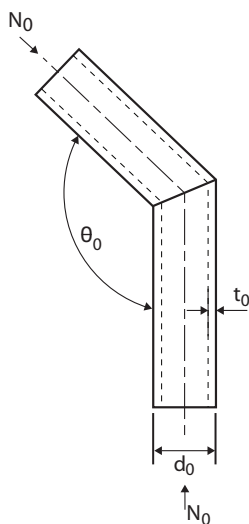

$$\text{Axial check: } N_{0,Ed} \leq 0.2 A_0 f_{y0}$$

$$\text{Shear check: } V_{0,Ed} \leq 0.5 V_{pl,0,Rd}$$

Axial and moment check:

$$\frac{N_{0,Ed}}{A_0 f_{y0}} + \frac{M_{ip,0,Ed}}{W_{pl,ip,0} f_{y0}} \leq \kappa$$

Where:

$$\kappa = \left[\frac{d_0}{20t_0} + 0.77 \right]^{-1.19} \times \sqrt{\frac{235}{f_{y0}}}$$

Values for κ are shown graphically in **figure 35** for grade S355 material.

Figure 35:

Un-reinforced circular knee joint reduction factor, κ for S355

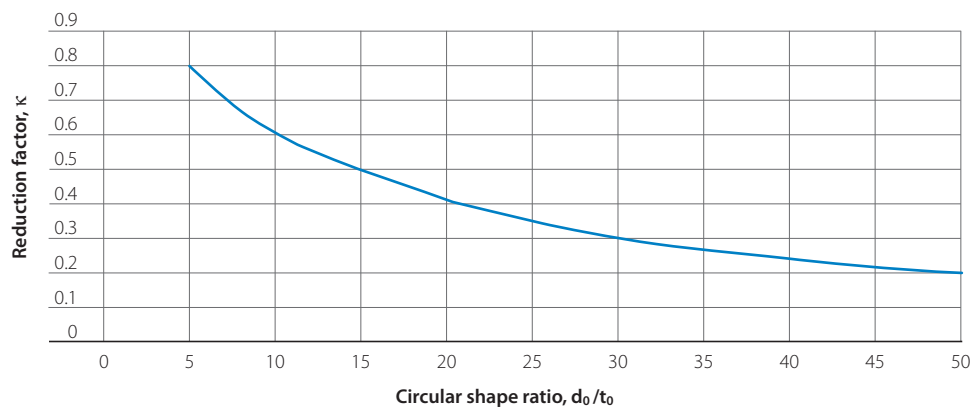
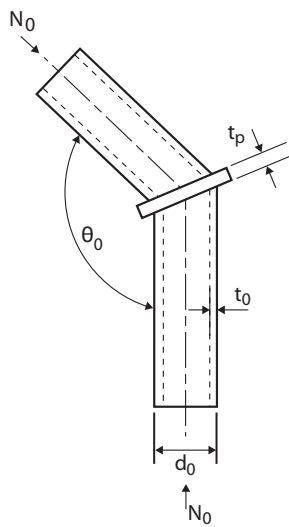

Figure 36:

Reinforced circular knee joint



Axial and moment check:

$$\frac{N_{0,Ed}}{A_0 f_{y0}} + \frac{M_{ip,0,Ed}}{W_{pl,ip,0} f_{y0}} \leq \kappa$$

Reduction factor, $\kappa = 1.0$ when reinforced with plate thickness, t_p within validity limits of **figure 33**.

As the reduction factor, $\kappa = 1.0$ the knee joint can achieve the full moment resistance of the circular section (plastic for class 1 and 2).



5.3 Rectangular hollow section chord joints

All dimensions used in the design formulae and validity limits are nominal.

5.3.1 Rectangular chord joint validity limits

Joints with rectangular chords should be within the validity range of **figure 37**;

Figure 37:

Rectangular hollow section joint validity limits

Joint type	Bracing type	Chord b_0/t_0 and h_0/t_0	Brace b_i/t_i & h_i/t_i or d_i/t_i		Brace/chord b_i/b_0 or d_i/b_0	Brace: chord h_0/b_0 and h_i/b_i	Eccentricity	Brace angle	Gap or overlap
			Comp'n	Tension					
T- and X-joints	Rectangular	≤ 35	≤ 35		≥ 0.25 but ≤ 1.0		–	–	–
K- and N-gap joints		and class 1 or 2	and class 1 or 2	≤ 35	≥ 0.35 and $\geq 0.1+0.01b_0/t_0$ but ≤ 1.0	≥ 0.5 but ≤ 2.0		$30^\circ \leq \theta_i \leq 90^\circ$	$g \geq t_1+t_2$ and $0.5 b_0(1-\beta) \leq g \leq 1.5 b_0(1-\beta)^{**}$
K- and N-overlap joints		class 1 or 2	class 1		≥ 0.25 but ≤ 1.0		$-0.55 h_0 \leq e \leq +0.25 h_0$		$25\% \leq \lambda_{ov}$ and $b_i/b_j \geq 0.75$
All types	Circular	As above		$d_i/t_i \leq 50$	$0.4 \leq d_i/b_0 \leq 0.8$				$25\% \leq \lambda_{ov}$ and $d_i/d_j \geq 0.75$
T-, Y- and X-joints	Transverse Plate and I- or H-section	$b_0/t_0 \leq 30$ and $h_0/t_0 \leq 35$ and class 1 or 2	–	–	$0.5 \leq b_i/b_0 \leq 1.0$	$0.5 \leq h_0/b_0 \leq 2.0$	–	$\theta_i \approx 90^\circ$	–
	Longitudinal plate				$t_i/b_0 \leq 0.2$ and $1 \leq h_i/b_0 \leq 4.0^*$				

* can be physically >4, but for calculation purposes should not be taken as >4

** if $g > 1.5b_0(1-\beta)$ treat as two separate T- or Y-joints and check the chord for shear between the bracings.

Section classification is for compression.

The angle between the chord and either a rectangular or a circular bracing and between bracings should be between 30° and 90° inclusive. Longitudinal and transverse plates should be at approximately 90°.

5.3.2 Rectangular chord joint factors

The following factors are used during the calculation of rectangular chord joint resistance:

5.3.2.1 Chord stress factor, k_n or k_m

For all joints except longitudinal gusset plate joints – see **figure 38**.

$$\text{For } n > 0 \text{ (compression):} \quad k_n = 1.3 - \frac{0.4n}{\beta} \quad \text{but } k_n \leq 1.0$$

$$\text{For } n \leq 0 \text{ (tension):} \quad k_n = 1.0$$

Figure 38:

Rectangular joint – Chord stress factor, k_n (All joints except longitudinal gusset plate)

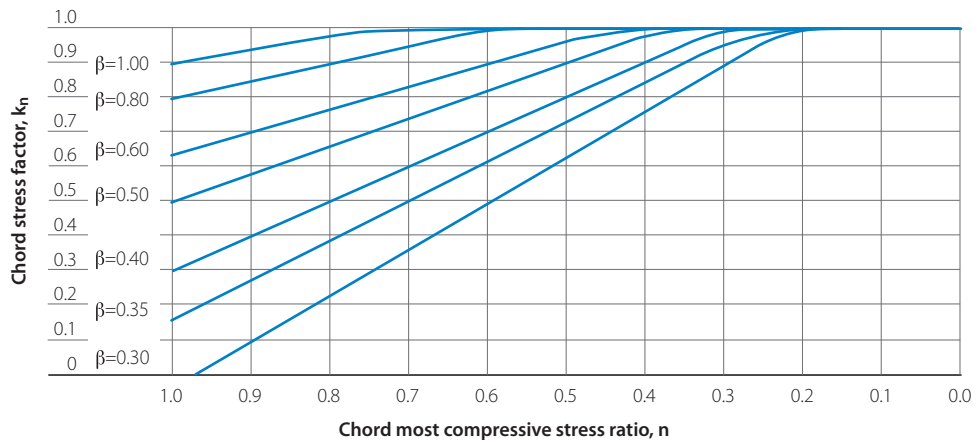

For longitudinal gusset plate joints only – see **figure 39**

For $n > 0$ (compression): $k_m = 1.3 (1 - n)$ but $k_m \leq 1.0$

For $n \leq 0$ (tension): $k_m = 1.0$

where:

$$n = (\sigma_{0,Ed} / f_{y0})$$

n is the most compressive applied factored stress ratio in the chord adjacent to the joint and is negative for tension

$$\sigma_{0,Ed} = \frac{N_{0,Ed}}{A_0} + \frac{|M_{ip,0,Ed}|}{W_{el,ip,0}} + \frac{|M_{op,0,Ed}|}{W_{el,op,0}}$$

$\sigma_{0,Ed}$ is the most compressive applied factored stress in the chord adjacent to the joint due to axial forces and moments and is negative for tension

Figure 39:

Rectangular joint – Chord stress factor, k_m (Longitudinal gusset plate joints only)

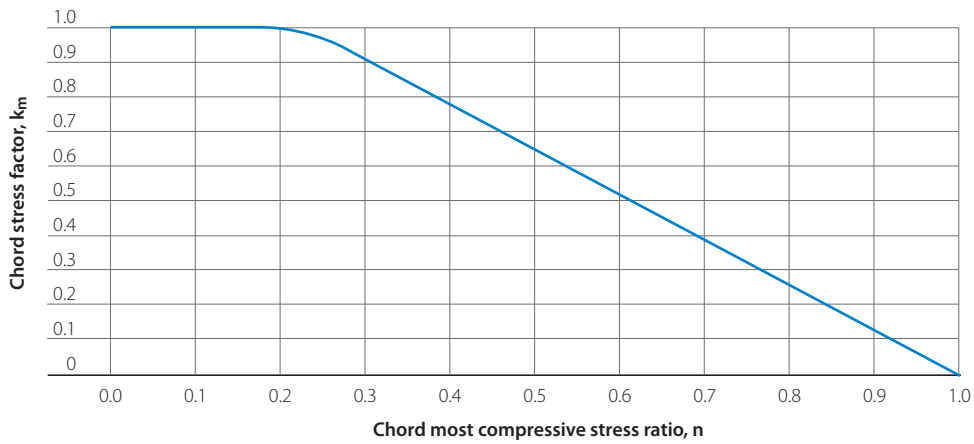

5.3.2.2 Bracing effective widths, b_{eff} , $b_{e,p}$ and $b_{e,ov}$

Brace effective width (brace to chord): $b_{eff,i} = \frac{10t_0}{b_0} \times \frac{f_{y0} t_0}{f_{yi} t_i} b_i$ but $b_{eff,i} \leq b_i$

$$b_{eff,j} = \frac{10t_0}{b_0} \times \frac{f_{y0} t_0}{f_{yj} t_j} b_j \text{ but } \leq b_j$$

Brace effective width (punching shear): $b_{e,p,i} = \frac{10t_0}{b_0} b_i$ but $b_{e,p,i} \leq b_i$

Brace effective width (brace to brace): $b_{e,ov} = \frac{10t_j}{b_j} \times \frac{f_{yj} t_j}{f_{yi} t_i} b_i$ but $b_{e,ov} \leq b_i$

(Suffix 'i' indicates brace 1,2,3 for gap joints or the overlapping brace in overlap joints)

(Suffix 'j' indicates the overlapped bracing)

5.3.2.3 Chord side wall buckling strength f_b – see figure 40

For tension in the bracing: $f_b = f_{y0}$

For compression in the bracing: $f_b = \chi f_{y0}$ (T- and Y-joints)
 $f_b = 0.8 \chi f_{y0} \sin\theta_i$ (X-joints)

The flexural buckling reduction factor, χ is obtained using strut curve 'a' for **Celsius®355** & strut curve 'c' for **Hybox®355** from EN 1993-1-1:2005, clause 6.3.1.2, Figure 6.4 where the non-dimensional slenderness is taken as:

$$\bar{\lambda} = 3.46 \frac{\left(\frac{h_0}{t_0} - 2\right) \sqrt{\frac{1}{\sin\theta_i}}}{\pi \sqrt{\frac{E}{f_{y0}}}}$$

Figure 40:

Reduction factor, χ for strut curves hot and cold to EN 1993-1-1:2005

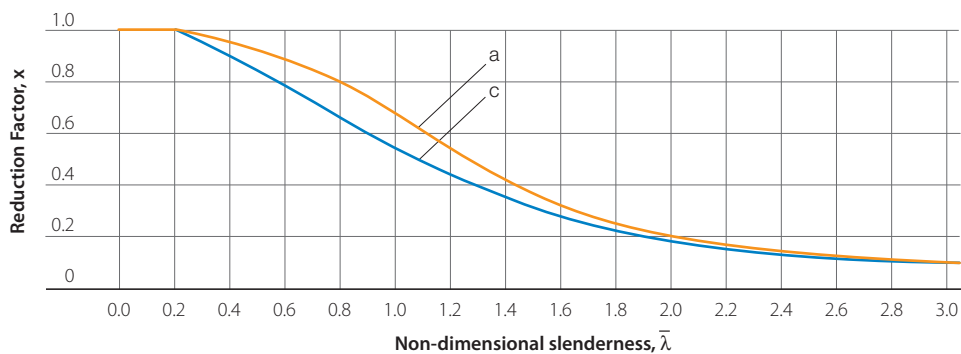

Key

Hot (orange square) Cold (blue square)

Alternatively, working to BS 5950-1:2000, replace χf_{y0} above with p_c from table 24 in BS 5950-1:2000 for strut curve 'a' or 'c' with the slenderness ratio as:

$$\lambda = 3.46 \frac{\left(\frac{h_0}{t_0} - 2\right)}{\sqrt{(\sin\theta_i)}}$$

5.3.2.4 Chord side wall crushing strength f_{yk}

for T- and Y-joints: $f_{yk} = f_{y0}$
 for X-joints: $f_{yk} = 0.8 f_{y0}$

5.3.2.5 Chord shear area, $A_{v,0}$

The chord shear area, $A_{v,0}$ in uniplanar K- and N-joints with a gap is dependent upon the type of bracings and the size of the gap.

$$A_{v,0} = (2 h_0 + \alpha b_0) t_0$$

where: for rectangular bracings: $\alpha = \sqrt{\frac{1}{1 + \frac{4g^2}{3t_0^2}}}$

for circular bracings, T-, Y- and X-joints: $\alpha = 0$

In multi-planar joints the sum of the shear area, $A_{v,0}$, for each plane of bracings should not exceed that total cross sectional area of the chord.

5.3.3 Rectangular chords and rectangular bracings with axial forces

A number of failure modes can be critical for rectangular chord joints. In this section the design formulae for all possible modes of failure, within the parameter limits, are given. The actual resistance of the joint should always be taken as the lowest of these joint resistances.

T-, Y- and X-joints

Chord face failure (valid when $\beta \leq 0.85$):
$$N_{1,Rd} = \frac{k_n f_{y0} t_0^2}{(1-\beta) \sin\theta_1} \left(\frac{2\eta}{\sin\theta_1} + 4\sqrt{(1-\beta)} \right) / \gamma_{M5}$$

Chord shear (valid for X-joints with $\cos\theta_1 > h_1/h_0$):
$$N_{1,Rd} = \frac{f_{y0} A_{v,0}}{\sqrt{3} \sin\theta_1} / \gamma_{M5}$$

where: $\alpha = 0$ in $A_{v,0}$

Chord side wall buckling (valid when $\beta = 1.0$):
$$N_{1,Rd} = \frac{k_n f_b t_0}{\sin\theta_1} \left(\frac{2h_1}{\sin\theta_1} + 10 t_0 \right) / \gamma_{M5}$$

for k_n see section 5.3.2.1

Chord punching shear (valid when $0.85 \leq \beta \leq 1 - 1/\gamma$):
$$N_{1,Rd} = \frac{f_{y0} t_0}{\sqrt{3} \sin\theta_1} \left(\frac{2h_1}{\sin\theta_1} + 2b_{e,p,1} \right) / \gamma_{M5}$$

Bracing effective width failure (valid when $\beta \geq 0.85$):
$$N_{1,Rd} = f_{y1} t_1 (2h_1 - 4t_1 + 2 b_{eff,1}) / \gamma_{M5}$$

For $0.85 < \beta < 1$ use linear interpolation between the resistance for chord face failure at $\beta = 0.85$ and the governing value for chord side wall failure (chord side wall buckling or chord shear) at $\beta = 1.0$, i.e.:

$$N_{1,Rd} = \frac{N_{1,Rd(csw)} - N_{1,Rd(cfd)}}{0.15} (\beta - 0.85) + N_{1,Rd(cfd)}$$

where: $N_{1,Rd(csw)}$ = lowest of chord side wall buckling or chord shear with $\beta = 1.0$

$N_{1,Rd(cfd)}$ = chord face failure resistance with $\beta = 0.85$

for k_n see section 5.3.2.1

for $b_{eff,1}$ & $b_{e,p,1}$ see section 5.3.2.2

for $A_{v,0}$ see section 5.3.2.5

K- and N-gap joints

In the formulae below subscript $i = 1$ or 2 as the formulae is applied to both bracings.

Chord face failure:
$$N_{i,Rd} = \frac{8.9 k_n f_{y0} t_0^2 \sqrt{\gamma}}{\sin \theta_i} \left(\frac{b_1 + b_2 + h_1 + h_2}{4b_0} \right) / \gamma_{M5}$$

Chord shear between bracings:
$$N_{i,Rd} = \frac{f_{y0} A_{v,0}}{\sqrt{3} \sin \theta_i} / \gamma_{M5}$$

Bracing effective width:
$$N_{i,Rd} = f_{yi} t_i (2h_i - 4t_i + b_i + b_{eff,i}) / \gamma_{M5}$$

Chord punching shear (valid when $\beta \leq 1 - 1/\gamma$):
$$N_{i,Rd} = \frac{f_{y0} t_0}{\sqrt{3} \sin \theta_i} \left(\frac{2h_i}{\sin \theta_i} + b_i + b_{e,p,i} \right) / \gamma_{M5}$$

Chord axial force resistance in the gap between the bracings: Check $N_{0,gap,Rd} \geq N_{0,gap,Ed}$

$$N_{0,gap,Rd} = \left[(A_0 - A_{v,0}) f_{y0} + A_{v,0} f_{y0} \sqrt{1 - (V_{0,Ed}/V_{pl,0,Rd})^2} \right] / \gamma_{M5}$$

where: $V_{0,Ed} = \text{maximum} |N_{1,Ed}| \sin \theta_1$ and $|N_{2,Ed}| \sin \theta_2$

$N_{0,gap,Ed} = \text{maximum of } N_{p,Ed} + N_{1,Ed} \cos \theta_1 \text{ and } N_{0,Ed} + N_{2,Ed} \cos \theta_2$

$$V_{pl,0,Rd} = \frac{A_{v,0} (f_{y0} / \sqrt{3})}{\gamma_{M0}}$$

for k_n see section 5.3.2.1

for $b_{eff,1}$ & $b_{e,p,1}$ see section 5.3.2.2

for $A_{v,0}$ see section 5.3.2.5

K- and N-overlap joints

Only the joint resistance of the overlapping bracing member, i, need be calculated using the formula below for the appropriate overlap.

Bracing effective width:

when $25\% \leq \lambda_{ov} < 50\%$:
$$N_{i,Rd} = f_{yi} t_i (b_{eff,i} + b_{e,ov} + 2h_i \frac{\lambda_{ov}}{50} - 4t_i) / \gamma_{M5}$$

when $50\% \leq \lambda_{ov} < 80\%$:
$$N_{i,Rd} = f_{yi} t_i (b_{eff,i} + b_{e,ov} + 2h_i - 4t_i) / \gamma_{M5}$$

when $\lambda_{ov} \geq 80\%$:
$$N_{i,Rd} = f_{yi} t_i (b_i + b_{e,ov} + 2h_i - 4t_i) / \gamma_{M5}$$

The resistance of the overlapped bracing member, j, is taken as:

$$N_{j,Rd} = N_{i,Rd} \frac{A_j f_{yj}}{A_i f_{yi}}$$

for $b_{eff,i}$ & $b_{e,ov}$ see section 5.3.2.2

Local shear of rectangular overlapping bracings:

when:

$60\% < \lambda_{ov} < 100\%$ and overlapped brace hidden seam is not welded.

$80\% < \lambda_{ov} < 100\%$ and overlapped brace hidden seam welded.

or $h_i < b_i$ or $h_j < b_j$

$$N_i \cos\theta_i + N_j \cos\theta_j \leq \left[\frac{f_{ui}}{\sqrt{3}} \times \frac{\left[\left(\frac{100 - \lambda_{ov}}{100} \right) 2h_i + b_{eff,i} \right] t_i}{\sin\theta_i} + \frac{f_{uj}}{\sqrt{3}} \times \frac{(2h_j + c_s b_{eff,j}) t_j}{\sin\theta_j} \right] / \gamma_{M5}$$

when $\lambda_{ov} \geq 100\%$:

$$N_i \cos\theta_i + N_j \cos\theta_j \leq \frac{f_{uj}}{\sqrt{3}} \times \frac{(2h_j + b_j + b_{eff,j}) t_j}{\sin\theta_j} / \gamma_{M5}$$

where: i = overlapping brace and j = overlapped brace

$c_s = 1$ when hidden toe is not welded

$c_s = 2$ when hidden toe is welded

for $b_{eff,i}$ & $b_{eff,j}$ see section 5.3.2.2

5.3.4 Rectangular chords and circular bracings with axial forces

For all the joints described in section 5.3.3, if the bracings are circular replace the bracing dimensions, b_i and h_i , with d_i and multiply the resulting resistance by $\pi/4$ (except for chord shear and chord axial force resistance in the gap). For local shear of overlapping circular bracings use formulae from section 5.1.3.

5.3.5 Rectangular chords and rectangular bracings with moments

Treat K- and N-gap joints as individual T-joints for moment joint resistance.

K- and N-overlap joints with moments are not covered in EN 1993-1-8 [3]. Tata Steel suggest checking these as individual T-joints then checking the footprint on the chord face made by both bracings as a T-joint in the absence of any other information.

5.3.5.1 T- and X-joints with in-plane moments

Chord face failure (valid when $\beta \leq 0.85$):

$$M_{ip,1,Rd} = k_n f_{y0} t_0^2 h_1 \left[\frac{1}{2\eta} + \frac{2}{\sqrt{1-\beta}} + \frac{\eta}{1-\beta} \right] / \gamma_{M5}$$

Chord side wall crushing (valid when $0.85 < \beta \leq 1.0$):

$$M_{ip,1,Rd} = 0.5 f_{yk} t_0 (h_1 + 5t_0)^2 / \gamma_{M5}$$

Bracing effective width (valid when $0.85 < \beta \leq 1.0$):

$$M_{ip,1,Rd} = f_{y1} \left[W_{pl,ip,1} - \left(1 - \frac{b_{eff,1}}{b_1} \right) b_1 (h_1 - t_1) t_1 \right] / \gamma_{M5}$$

for k_n see section 5.3.2.1

for $b_{eff,1}$ see section 5.3.2.2

for f_{yk} see section 5.3.2.4

5.3.5.2 T- and X-joints with out-of-plane moments

Chord face failure (valid when $\beta \leq 0.85$):

$$M_{op,1,Rd} = k_n f_{y0} t_0^2 \left[\frac{h_1 (1 + \beta)}{2 (1 - \beta)} + \sqrt{\frac{2 b_0 b_1 (1 + \beta)}{1 - \beta}} \right] / \gamma_{M5}$$

Chord side wall crushing (valid when $0.85 < \beta \leq 1.0$):

$$M_{op,1,Rd} = f_{yk} t_0 (b_0 - t_0) (h_1 + 5t_0) / \gamma_{M5}$$

Bracing effective width failure (valid when $0.85 < \beta \leq 1.0$):

$$M_{op,1,Rd} = f_{y1} \left[W_{pl,op,1} - 0.5 \left(1 - \frac{b_{eff,1}}{b_1} \right)^2 b_1^2 t_1 \right] / \gamma_{M5}$$

Chord distortional failure (lozenging) (valid for T-joints only):
 (This failure mode does not apply if chord distortional failure is prevented by other means)

$$M_{op,1,Rd} = 2 f_{y0} t_0 \left[h_1 t_0 + \sqrt{b_0 h_0 t_0 (b_0 + h_0)} \right] / \gamma_{M5}$$

for k_n see section 5.3.2.1
 for $b_{eff,1}$ see section 5.3.2.2
 for f_{yk} see section 5.3.2.4

5.3.6 Rectangular chords with transverse gusset plate

Plate effective width failure: $N_{1,Rd} = f_{y1} t_1 b_{eff,1} / \gamma_{M5}$

Chord face failure (valid when $\beta \leq 0.85$): $N_{1,Rd} = k_n f_{y0} t_0^2 \frac{2 + 2.8\beta}{\sqrt{1 - 0.9\beta}} / \gamma_{M5}$

Chord side wall crushing (valid when $b_1 \geq b_0 - 2t_0$): $N_{1,Rd} = k_n f_{y0} t_0 (2t_1 + 10t_0) / \gamma_{M5}$

Chord punching shear (valid when $b_1 \leq b_0 - 2t_0$): $N_{1,Rd} = \frac{f_{y0} t_0}{\sqrt{3}} (2t_1 + 2 b_{e,p,1}) / \gamma_{M5}$

In-plane moment resistance: $M_{ip,1,Rd} = 0.5 N_{1,Rd} t_1$

Out-of-plane moment resistance: $M_{op,1,Rd} = 0.5 N_{1,Rd} b_1$

for k_n see section 5.3.2.1
 for $b_{eff,1}$ & $b_{e,p,1}$ see section 5.3.2.2

Figure 41:

Transverse gusset plate

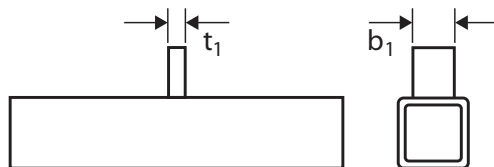

5.3.7 Rectangular chords with longitudinal gusset plate

Chord face failure:
$$N_{1,Rd} = k_m f_{y0} t_0^2 \left[\frac{2h_1}{b_0} + 4 \sqrt{1-t_1/b_0} \right] / \gamma_{M5}$$

In-plane moment resistance:
$$M_{ip,1,Rd} = 0.5 N_{1,Rd} h_1$$

Out-of-plane moment resistance:
$$M_{op,1,Rd} = 0.5 N_{1,Rd} t_1$$

for k_m see section 5.3.2.1

Figure 42:

Longitudinal gusset plate

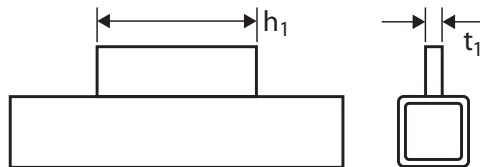

5.3.8 Rectangular chords with I- or H-section bracings

Conservatively, the resistance of an I- or H-section on a rectangular chord can be assumed as two transverse plates based on the dimensions of the flanges.

When $\eta \geq 2 \sqrt{1-\beta}$:

Plate effective width:
$$N_{1,Rd} = 2f_{y1} t_1 b_{eff,1} / \gamma_{M5}$$

Chord face failure (valid when $\beta \leq 0.85$):
$$N_{1,Rd} = 2k_n f_{y0} t_0^2 \frac{2 + 2.8\beta}{\sqrt{1-0.9\beta}} / \gamma_{M5}$$

Chord side wall crushing (valid when $b_1 \geq b_0 - 2t_0$):
$$N_{1,Rd} = 2k_n f_{y0} t_0 (2t_1 + 10t_0) / \gamma_{M5}$$

Chord punching shear (valid when $b_1 \leq b_0 - 2t_0$):
$$N_{1,Rd} = \frac{2f_{y0} t_0}{\sqrt{3}} (2t_1 + 2 b_{e,p,1}) / \gamma_{M5}$$

In-plane moment resistance:
$$M_{ip,1,Rd} = 0.5 N_{1,Rd} (h_1 - t_1)$$

Out-of-plane moment resistance:
$$M_{op,1,Rd} = 0.5 N_{1,Rd} b_1$$

for k_n see section 5.3.2.1

for $b_{eff,1}$ & $b_{e,p,1}$ see section 5.3.2.2

Figure 43:

I- or H-section bracing

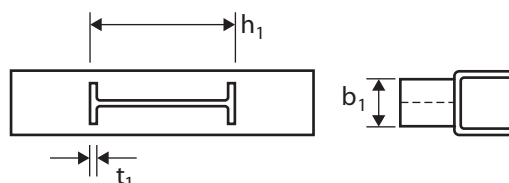

5.4 Knee joints in rectangular hollow sections

All dimensions used in the design formulae and validity limits are nominal.

5.4.1 Rectangular welded knee joint validity limits

Knee joints with circular chords should be within the validity range of **figure 44**:

Figure 44:

Rectangular knee joint validity limits

Knee Joint type	b_0 / t_0 and h_0 / t_0	t_p	Brace angle
Un-reinforced	class 1	-	90°
Reinforced	class 1 or 2	$1.5 t_0$ but $\geq 10 \text{ mm}$	$\leq \theta_0 < 180$

Section classification is for pure bending

Different size rectangular hollow sections should not be used. If different thickness rectangular hollow sections are to be welded then the thinner tube thickness should be used in the formulae.

Figure 45:

Un-reinforced rectangular knee joint

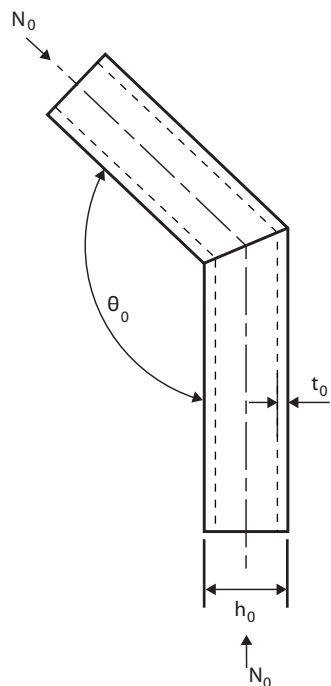

Axial check: $N_{0,Ed} \leq 0.2 A_0 f_{y0}$

Axial and moment check:
$$\frac{N_{0,Ed}}{A_0 f_{y0}} + \frac{M_{ip,0,Ed}}{W_{pl,ip,0} f_{y0}} \leq \kappa$$

For $\theta_0 \leq 90^\circ$:

$$\kappa = \frac{3 \sqrt{\frac{b_0}{h_0}}}{\left(\frac{b_0}{t_0}\right)^{0.8}} + \frac{1}{1+2\left(\frac{b_0}{h_0}\right)}$$

For $90^\circ < \theta_0 \leq 180^\circ$:

$$\kappa = 1 - \left[\sqrt{2} \cos\left(\frac{\theta_0}{2}\right) \right] (1 - \kappa_{90})$$

Where: κ_{90} is the value κ for $\theta_0 = 90^\circ$.

For $\theta_0 \leq 90^\circ$ values for κ are shown graphically in **figure 46**.

For $\theta_0 > 90^\circ$ values for κ are shown graphically in **figure 47**.

Figure 46:

Rectangular knee joint efficiency for $\theta_0 \leq 90^\circ$

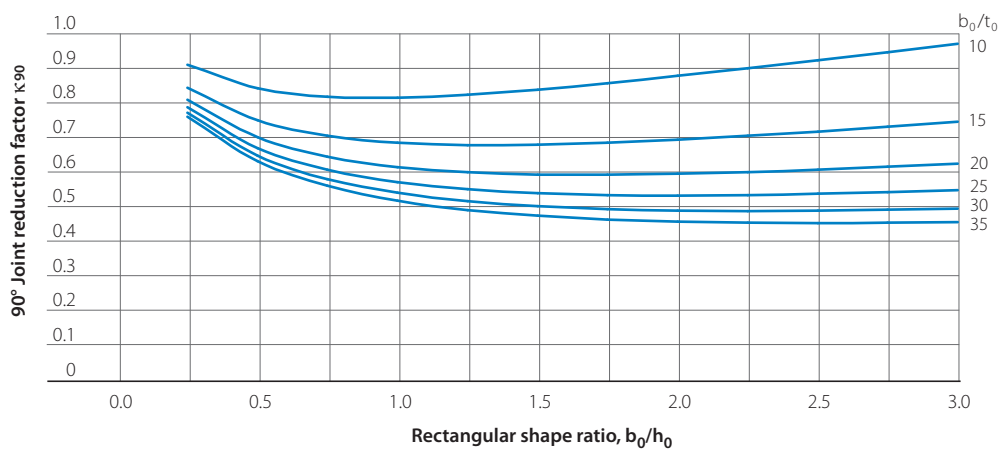

Figure 47:

Rectangular knee joint efficiency for $\theta_0 > 90^\circ$

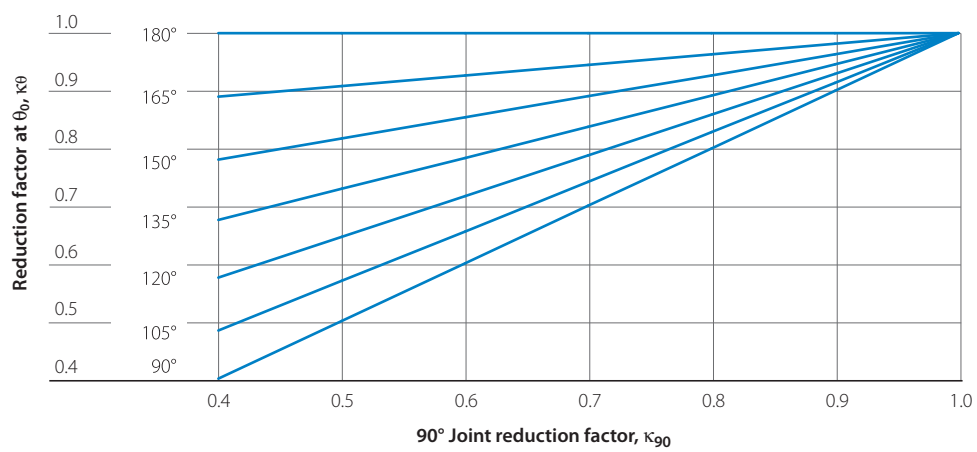
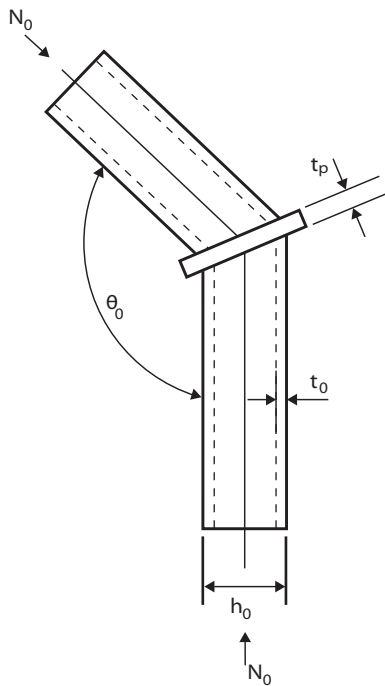

Figure 48:

Reinforced rectangular knee joint



Axial and moment check:

$$\frac{N_{0,Ed}}{A_0 f_{y0}} + \frac{M_{ip,0,Ed}}{W_{pl,ip,0} f_{y0}} \leq \kappa$$

Reduction factor, $\kappa = 1.0$ when reinforced with plate thickness, t_p within validity limits of **figure 44**.

As the reduction factor, $\kappa = 1.0$ the knee joint can achieve the full moment resistance of the rectangular hollow section (plastic for class 1 and 2 in pure bending).

5.5 Unidirectional K- and N-joints

All dimensions used in the design formulae and validity limits are nominal.
Suffix 'j' indicates the overlapped bracing and 'i' the overlapping bracing.

If both bracings of a K- and N-joint act in the same direction, e.g. both in compression or both in tension, the standard K- and N-joint formulae are not valid. In this situation it is suggested to check the K- and N-joint as a T-joint using one equivalent bracing on the chord. The equivalent bracing size is based on the footprint produced by the combined two bracings on the chord. We suggest a method of calculating this equivalent bracing size and therefore calculating the joint resistance.

Figure 49:

Unidirectional K-joint

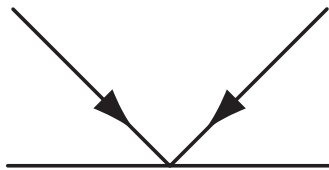

5.5.1 Equivalent bracing for circular bracings on circular or rectangular chord

Calculate footprint perimeter, P_i for each bracing assuming a flat chord face, even for a circular chord, alternatively obtain P_i from **figure 50**.

$$\text{Bracing footprint perimeter: } P_i = \frac{d_i}{2} \left[1 + \frac{1}{\sin\theta_i} + 3 \sqrt{1 + \left(\frac{1}{\sin\theta_i} \right)^2} \right]$$

Calculate a single equivalent combined bracing perimeter based on the overall footprint of both bracings:

For gap joints and overlap joints with $\lambda_{ov} < 80\%$:

$$\text{Equivalent combined bracing perimeter: } P_{eq} = \frac{P_1}{2} + \frac{P_2}{2} + 2 \left[\frac{d_1}{2\sin\theta_1} + g + \frac{d_2}{2\sin\theta_2} \right]$$

where: g = gap (+) or overlap (-)

for $\lambda_{ov} \geq 80\%$:

$$\text{Equivalent combined bracing perimeter: } P_{eq} = P_j$$

(suffix 'j' indicates the overlapped bracing)

P_j can be calculated using formula for P_i for overlapped brace

Maximum equivalent single bracing diameter: $d_{max} = \frac{P_{eq}}{\pi}$

Minimum equivalent single bracing diameter: $d_{min} = \frac{d_1 + d_2}{2}$

Equivalent single bracing diameter: $d_{eq} = \frac{d_{max} + d_{min}}{2}$ but $d_{eq} \leq d_0$

Equivalent single bracing height: $h_{eq} = \frac{d_1}{2\sin\theta_1} + g + \frac{d_2}{2\sin\theta_2}$

Figure 50:

Length of footprint perimeter, P_i (mm) for circular bracing on flat face

Bracing diameter d_i (mm)	Angle of intersection θ_i										
	30°	35°	40°	45°	50°	55°	60°	65°	70°	80°	90°
26.9	131	118	109	102	97	94	91	88	87	85	85
33.7	164	148	137	128	122	117	114	111	109	106	106
42.4	206	186	172	161	153	147	143	139	137	133	133
48.3	234	212	196	184	175	168	163	159	156	152	152
60.3	293	265	244	229	218	210	203	198	194	190	189
76.1	369	334	308	290	275	265	256	250	245	239	239
88.9	432	390	360	338	322	309	299	292	286	280	279
114.3	555	501	463	435	414	397	385	376	368	360	359
139.7	678	613	566	532	506	486	471	459	450	439	439
168.3	817	738	682	640	609	585	567	553	542	529	529
193.7	940	850	785	737	701	674	653	636	624	609	609
219.1	1064	961	888	834	793	762	738	720	706	689	688
244.5	1187	1073	991	930	885	850	824	803	788	769	768
273.0	1325	1198	1106	1039	988	949	920	897	880	859	858
323.9	1572	1421	1312	1232	1172	1126	1091	1064	1044	1019	1018
355.6	1726	1560	1441	1353	1287	1237	1198	1168	1146	1119	1117
406.4	1973	1783	1647	1546	1471	1413	1369	1335	1310	1278	1277
457.0	2218	2005	1852	1739	1654	1589	1539	1501	1473	1437	1436
508.0	2466	2228	2058	1933	1839	1767	1711	1669	1637	1598	1596

5.5.2 Equivalent bracing for rectangular bracings on rectangular chord

Calculate the equivalent single bracing width and length for a T-joint length to use in the T-joint resistance formulae.

$$\text{Equivalent single bracing breadth: } b_{eq} = \frac{b_1 + b_2}{2}$$

$$\text{Equivalent single bracing length: } h_{eq} = \frac{h_1}{\sin\theta_1} + g + \frac{h_2}{\sin\theta_2}$$

where: g = gap (+) or overlap (-)

$$\text{Equivalent combined bracing perimeter: } P_{eq} = 2 (b_{eq} + h_{eq})$$

5.5.3 Equivalent bracing T-joint resistance for circular chord

The equivalent bracing is taken as 90° to the chord.

$$\text{Chord face failure: } N_{eq,Rd} = \gamma^{0.2} k_p f_{y0} t_0^2 (2.8 + 14.2\beta^2) / \gamma_{M5}$$

$$\text{where: } \beta = \frac{d_{eq}}{d_0}$$

for k_p see section 5.1.2.1

$$\text{Chord punching shear (valid when } d_{min} \leq d_0 - 2 t_0): N_{eq,Rd} = \frac{f_{y0}}{\sqrt{3}} t_0 P_{eq} / \gamma_{M5}$$

5.5.4 Equivalent bracing T-joint resistance for rectangular chord

The equivalent bracing is taken as 90° to the chord.

$$\text{Chord face failure (valid when } \beta \leq 0.85): N_{eq,Rd} = \frac{k_n f_{y0} t_0^2}{(1-\beta)} (2\eta + 4\sqrt{1-\beta}) / \gamma_{M5}$$

$$\text{Chord side wall buckling (valid when } \beta = 1.0): N_{eq,Rd} = k_n f_b t_0 (2h_{eq} + 10t_0) / \gamma_{M5}$$

For $0.85 < \beta < 1.0$ use linear interpolation between the chord face failure and chord side wall buckling resistance above.

Chord punching shear (valid when $0.85 \leq \beta \leq 1 - 1/\gamma$):

$$N_{eq,Rd} = \frac{f_{y0} t_0}{\sqrt{3}} P_{eq}/\gamma_{M5}$$

where:

$$\eta = \frac{h_{eq}}{b_0}$$

for k_n see section 5.3.2.1

for rectangular bracings:
$$\beta = \frac{b_{eq}}{b_0}$$

for circular bracings:
$$\beta = \frac{d_{min}}{b_0}$$

Note: It is not necessary to multiply the joint resistances for circular bracings onto rectangular chords by $\pi/4$ in the above formula as the method is based on the circular bracing perimeters.

for k_n see section 5.3.2.1

for f_b see section 5.3.2.3

5.5.5 Proportioning equivalent bracing T-joint resistance into individual bracings

The equivalent single bracing T-joint resistance needs to be divided between the two actual bracings in proportion to their individual applied forces, $N_{i,Ed}$ and bracing to chord angles:

Joint resistance for individual bracings;

$$N_{1,Rd} = N_{eq,Rd} \frac{N_{1,Ed}}{(N_{1,Ed} \sin\theta_1 + N_{2,Ed} \sin\theta_2)}$$

$$N_{2,Rd} = N_{eq,Rd} \frac{N_{2,Ed}}{(N_{1,Ed} \sin\theta_1 + N_{2,Ed} \sin\theta_2)}$$

5.5.6 Additional checks required

In addition to the above, each individual bracing must be checked as a T- or Y-joint using the standard formulae. In this check the circular bracing on a rectangular chord will need to be multiplied by $\pi/4$.

In overlap joints, the overlapping bracing should also be checked as a T- or Y-joint with the overlapped bracing as the chord, using the standard T- or Y-joint formulae.

5.6 KT-joints

All dimensions used in the design formulae and validity limits are nominal. Suffix 'j' indicates the overlapped bracing and 'i' the overlapping bracing.

KT-joints often occur in warren trusses where verticals are used to reduce the effective length of the top chord. The KT-joint advice in EN 1993-1-8:2005 only covers one brace force direction combination. As gap/overlap, section type and bracing force combination affects the method of assessment, we felt further advice was required.

The following suggested method is based on recommendations in EN 1993-1-8:2005.

5.6.1 Vertical brace opposite direction to both diagonal bracings – Figure 51(a), (b), (e) and (f)

Check bracings 1 and 3 as a normal K- and N-joint using the standard formulae for gap or overlap types of joint. Repeat for bracings 2 and 3. For types **figure 51**(e) to (f), check cross chord loading as described in section 5.6.3.

5.6.2 One diagonal brace opposite direction to other two bracings – Figure 51(c), (d), (g) and (h)

Follow the advice below depending on gap/overlap and section type.

For types **figure 51**(g) and (h), check cross chord loading as described in section 5.6.3.

KT-gap joints, circular and rectangular

The resistance of gap joints can be related to K- and N-joints by modifying the chord face deformation formula by replacing:

for circular bracings: $\frac{d_1}{d_0}$ with $\frac{d_1 + d_2 + d_3}{3 d_0}$

for rectangular bracings: $\frac{b_1 + b_2 + h_1 + h_2}{4 b_0}$ with $\frac{b_1 + b_2 + b_3 + h_1 + h_2 + b_3}{6 b_0}$

The joint should be checked for all the relevant joint failure modes.

Figure 51:

Eight bracing force combinations of KT-joint

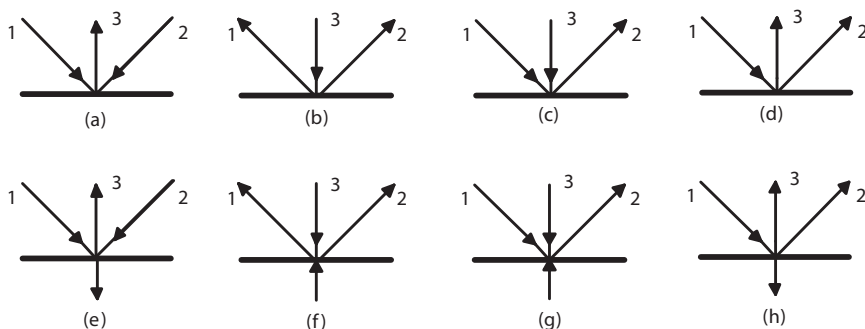

The gap should be taken as the largest gap between two bracing members having significant forces acting in the opposite direction. If the vertical bracing member in a gap KT-joint has no force in it, the gap should be taken as the distance between the toes of members 1 and 2, and the joint treated as a standard K- and N-joint using the standard chord face deformation formula.

The force components, normal to the chord, of the two members acting in the same sense are added together to represent the force. This should be less than, or equal to, the joint resistance component, normal to the chord, of the most highly loaded compressive member, normally $N_{1,Rd}$. The single member acting in the opposite sense to the other two members should also be checked to ensure its force component is less than or equal to this joint resistance component.

For example **figure 51(c)**:

$$N_{1,Ed} \sin \theta_1 + N_{3,Ed} \sin \theta_3 \leq N_{1,Rd} \sin \theta_1$$

$$N_{2,Ed} \sin \theta_2 \leq N_{1,Rd} \sin \theta_1$$

For example **figure 51(d)**:

$$N_{2,Ed} \sin \theta_2 + N_{3,Ed} \sin \theta_3 \leq N_{1,Rd} \sin \theta_1$$

$$N_{1,Ed} \sin \theta_1 \leq N_{1,Rd} \sin \theta_1$$

where:

$N_{1,Rd}$ is the calculated joint resistance.

Overlap KT-Joints, circular chord

Overlaps are more likely to occur with N-joints and hence KT-joints are usually overlapping. Circular overlap KT-joints are treated in the same way as circular gap KT-joints but use the smallest overlap between bracings. The procedure is easier than rectangular KT-joints as they only need be checked for chord face failure, calculated for the most highly loaded compressive bracing, usually $N_{1,Rd}$.

Overlap KT-Joints, rectangular chord

Rectangular overlap KT-joint resistance can be determined by checking each overlapping bracing member and ensuring that $N_{i,Ed} \leq N_{i,Rd}$ where $N_{i,Rd}$ is the calculated joint resistance.

The resistance of the overlapped bracing member, subscript j, should be taken as equal to that of the overlapping member based on the efficiency ratio of the overlapping bracing to the overlapped bracing, i.e:

$$\text{Overlapped bracing joint resistance: } N_{j,Rd} = N_{i,Rd} \frac{A_j f_{yj}}{A_i f_{yi}}$$

For the overlapping bracing member effective width formulae, care should be taken to ensure that the member sequence of overlapping is properly accounted for. The overlapping bracing faces for effective width are designated as:

b_i or $b_{\text{eff},i}$ is the face locating onto the chord

$b_{\text{e,ov}}$ is the face locating onto the overlapped bracing.

These effective width terms in the overlapping bracing resistance formulae are added together, e.g. $b_{\text{eff},i} + b_{\text{e,ov}}$ and $b_i + b_{\text{e,ov}}$ for overlaps $\geq 80\%$, and assumes that only one face is overlapping. So, if the overlapping bracing is in the middle, and overlaps both diagonals as in **figure 52**, the standard overlapping K-joint formula should be modified accordingly, i.e:

Figure 52:

KT-joint with central overlapping bracing

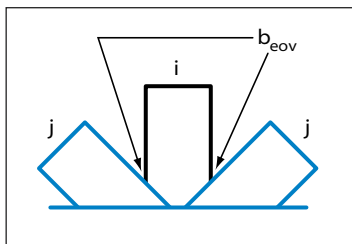

$25\% \leq \lambda_{\text{ov}} < 50\%$:

$$N_{i,Rd} = f_{yi} t_i \left(b_{\text{eff},i} + b_{\text{e,ov}} + 2h_i \frac{\lambda_{\text{ov}}}{50} - 4t_i \right) / \gamma_{M5}$$

$\lambda_{\text{ov}} \geq 50\%$:

$$N_{i,Rd} = f_{yi} t_i \left(2b_{\text{e,ov}} + 2h_i - 4t_i \right) / \gamma_{M5}$$

Figure 53:

KT-joint with outer diagonal overlapping bracings

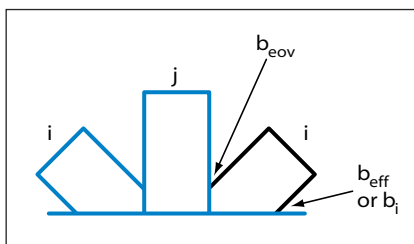

If the two outer diagonal bracings are the overlapping bracings, as in **figure 53**, then the configuration uses the standard K-Joint overlapping formulae.

5.6.3 Cross Chord Loading: circular and rectangular

KT-joints with cross chord loading (i.e. X-joint loading), as in **figure 51** (e) to (h), should be treated as per the advice above depending on the gap/overlap, section type and brace force direction combination. However, an additional check should be made for the purlin or hanger joint. The joint should be checked as an X-joint using an equivalent bracing member size for the KT bracings based on the bracings footprint on the chord (refer to 5.5 'Unidirectional K- and N-joints'). Generally, in this case, the purlin or hanger side will be the critical part as it is likely to be a smaller footprint.

5.7 I- or H-section chord joints

All dimensions used in the design formulae and validity limits are nominal. Suffix 'j' indicates the overlapped bracing and 'i' the overlapping bracing.

Figure 54:

I- or H-section chord with rectangular bracing

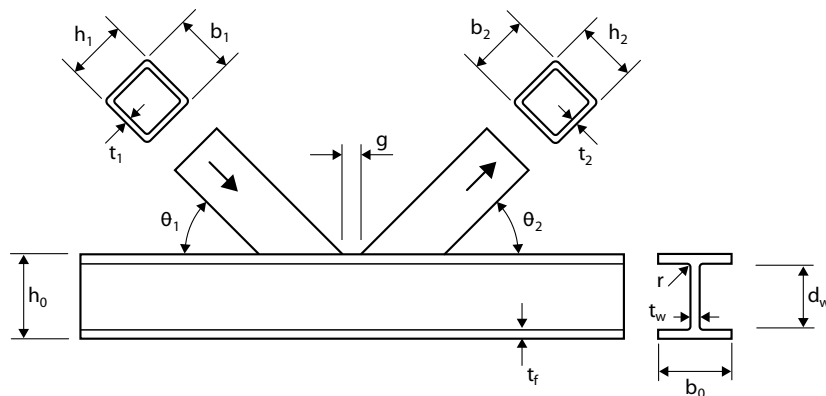

5.7.1 I- or H-section chord joint validity limits

I- or H-section chord joints should be within the validity range of figure 55:

Figure 55:

I- or H-section chord joint validity limits

Joint type	Chord b_0/t_f	Chord web d_w/t_w	Brace b_i/t_i & h_i/t_i or d_i/t_i		Brace h_i/b_i	Gap or overlap	Brace angle
			Comp'n	Tension			
X-joints	Class 1 or 2	$d_w \leq 400\text{mm}$ and Class 1			≥ 0.5 but ≤ 2.0	-	$30^\circ \leq \theta_i \leq 90^\circ$
T- and Y-joints		$h_i/t_i \leq 35$					
K- and N-gap joints		$d_w \leq 400\text{mm}$ and Class 1 or 2	$b_i/t_i \leq 35$	$h_i/t_i \leq 35$			
K- and N-overlap joints			$d_i/t_i \leq 50$ and Class 1 or 2	$b_i/t_i \leq 35$	$h_i/t_i \leq 35$	1.0	
					≥ 0.5 but ≤ 2.0	$25\% \leq \lambda_{ov}$ $b_i/b_j \geq 0.75$ $d_i/d_j \geq 0.75$	

Section classification is for compression

5.7.2 I- or H- section chord joint factors

Bracing effective width factors

Brace effective width (brace to chord): $p_{eff,i} = t_w + 2r + 7t_f \frac{f_{y0}}{f_{yi}}$

but for T-, Y-, X-joints and K- and N-gap joints: $p_{eff,i} \leq b_i + h_i - 2 t_i$

but for K- and N-overlap joints: $p_{eff,i} \leq b_i$

Overlap bracing effective width (rectangular bracings): $b_{e,ov} = \frac{10t_j}{b_j} \times \frac{f_{yj} t_j}{f_{yi} t_i} \times b_i$

but: $b_{e,ov} \leq b_i$

Overlap bracing effective width (circular bracings): $d_{e,ov} = \frac{12t_j}{d_j} \times \frac{f_{yj} t_j}{f_{yi} t_i} \times d_i$

Chord web effective width: $b_{w,i} = \frac{h_i}{\sin\theta_i} + 5(t_f + r)$

but: $b_{w,i} \leq 2 t_i + 10(t_f + r)$

5.7.3 Chord shear area, $A_{v,0}$

The chord shear area, $A_{v,0}$ in K- and N-joints with a gap is dependent upon the type of bracings and the size of the gap.

Chord shear area, $A_{v,0} = A_0 - (2 - \alpha)b_0 t_f + (t_w + 2r) t_f$

where: for rectangular bracings: $\alpha = \frac{1}{\sqrt{\left(1 + \frac{4g^2}{3 t_f^2}\right)}}$

for circular bracings: $\alpha = 0$

5.7.4 I- or H-section chords and rectangular bracings with axial forces

T-, Y- and X-joints

Chord web yielding:
$$N_{1,Rd} = \frac{f_{y0} t_w b_{w,1}}{\sin\theta_1} / \gamma_{M5}$$

Bracing effective width failure:
$$N_{1,Rd} = 2f_{y1} t_1 p_{eff,1} / \gamma_{M5}$$

K- and N-gap joints

Chord web yielding:
$$N_{i,Rd} = \frac{f_{y0} t_w b_{w,i}}{\sin\theta_i} / \gamma_{M5}$$

Chord shear:
$$N_{i,Rd} = \frac{f_{y0} A_{v,0}}{\sqrt{3} \sin\theta_i} / \gamma_{M5}$$

Bracing effective width:
$$N_{i,Rd} = 2f_{yi} t_i p_{eff,i} / \gamma_{M5}$$

The bracing effective width failure criterion, above, does not need to be checked provided that:

$$\frac{g}{t_f} \leq 20-28\beta : \beta \leq 1.0-0.03\gamma : 0.75 \leq \frac{b_1}{b_2} \leq 1.33 : 0.75 \leq \frac{d_1}{d_2} \leq 1.33$$

Chord axial force resistance in the gap between the bracings:

Check:
$$N_{0,gap,Rd} \geq N_{0,gap,Ed}$$

$$N_{0,gap,Rd} = \left[(A_0 - A_{v,0}) f_{y0} + A_{v,0} f_{y0} \sqrt{1 - \left(\frac{V_{0,Ed}}{V_{pl,0,Rd}} \right)^2} \right] / \gamma_{M5}$$

where:
$$V_{0,Ed} = \text{maximum of } |N_{1,Ed}| \sin \theta_1 \text{ and } |N_{2,Ed}| \sin \theta_2$$

$$V_{pl,0,Rd} = \frac{A_{v,0} (f_{y0} / \sqrt{3})}{\gamma_{M0}}$$

for $b_{w,i}$ and $p_{eff,i}$ see section 5.7.2

K- and N-overlap joints

Only the joint resistance of the overlapping bracing member, i, need be calculated using the formula below for the appropriate bracing angle.

Bracing effective width:

$$\text{when } 25\% \leq \lambda_{ov} < 50\%: \quad N_{i,Rd} = f_{yi} t_i \left(p_{eff,i} + b_{e,ov} + 2h_i \frac{\lambda_{ov}}{50} - 4t_i \right) / \gamma_{M5}$$

$$\text{when } 50\% \leq \lambda_{ov} < 80\%: \quad N_{i,Rd} = f_{yi} t_i (p_{eff,i} + b_{e,ov} + 2h_i - 4t_i) / \gamma_{M5}$$

$$\text{when } \lambda_{ov} \geq 80\%: \quad N_{i,Rd} = f_{yi} t_i (b_i + b_{e,ov} + 2h_i - 4t_i) / \gamma_{M5}$$

The resistance of the overlapped bracing member, j, is taken as:

$$\text{Overlapped bracing joint resistance:} \quad N_{j,Rd} = N_{i,Rd} \frac{A_j f_{yj}}{A_i f_{yi}}$$

Local shear of circular overlapping bracings:

when:

60% < λ_{ov} < 100% and overlapped brace hidden seam is not welded

80% < λ_{ov} < 100% and overlapped brace hidden seam is welded

$$N_i \cos\theta_i + N_j \cos\theta_j \leq \frac{\pi}{4} \left[\frac{f_{ui}}{\sqrt{3}} \times \frac{\left[\left(\frac{100 - \lambda_{ov}}{100} \right) 2d_i + d_{eff,i} \right] t_i}{\sin\theta_i} + \frac{f_{uj}}{\sqrt{3}} \times \frac{(2d_j + c_s d_{eff,j}) t_j}{\sin\theta_j} \right] / \gamma_{M5}$$

when $\lambda_{ov} \geq 100\%$:

$$N_i \cos\theta_i + N_j \cos\theta_j \leq \frac{f_{uj}}{\sqrt{3}} \times \frac{\pi}{4} \times \frac{(3d_j + d_{eff,j}) t_j}{\sin\theta_j} / \gamma_{M5}$$

where: i = overlapping brace and j = overlapped brace
 $c_s = 1$ when hidden toe is not welded
 $c_s = 2$ when hidden toe is welded

for $p_{eff,i}$ see section 5.7.2

for $d_{eff,j}$ see section 5.1.2.3

Local shear of rectangular overlapping bracings:

when:

60% < λ_{OV} < 100% and overlapped brace hidden seam is not welded.

80% < λ_{OV} < 100% and overlapped brace hidden seam welded.

or $h_i < b_i$ or $h_j < b_j$

$$N_i \cos\theta_i + N_j \cos\theta_j \leq \frac{f_{ui}}{\sqrt{3}} \times \frac{\left[\left(\frac{100 - \lambda_{OV}}{100} \right) 2h_i + b_{eff,i} \right] t_i}{\sin\theta_i} + \frac{f_{uj}}{\sqrt{3}} \times \frac{(2h_j + c_s b_{eff,j}) t_j}{\sin\theta_j} / \gamma_{M5}$$

when $\lambda_{OV} \geq 100\%$:

$$N_i \cos\theta_i + N_j \cos\theta_j \leq \frac{f_{uj}}{\sqrt{3}} \times \frac{(2h_j + b_j + b_{eff,j}) t_j}{\sin\theta_j} / \gamma_{M5}$$

where: i = overlapping brace and j = overlapped brace

$c_s = 1$ when hidden toe is not welded

$c_s = 2$ when hidden toe is welded

for $b_{eff,i}$ and $b_{eff,j}$ see section 5.3.2.2

5.7.5 I- or H- section chords and rectangular bracings with in-plane moments

For I- or H-section chord joints the internal design moment, $M_{ip,1,Ed}$ may be taken as the value at the point where the centreline of the bracing intersects with the chord face.

T-, Y- and X-joints

Chord web failure: $M_{ip,1,Rd} = 0.5 f_{y0} t_w b_{w,1} (h_1 - t_1) / \gamma_{M5}$

Bracing effective width: $M_{ip,1,Rd} = f_{y1} t_1 p_{eff,1} (h_1 - t_1) / \gamma_{M5}$

for $p_{eff,i}$ and $b_{w,1}$ see section 5.7.2

K- and N-gap joints

Treat as two separate T- or Y-joints.

5.7.6 I- or H- section chords and circular bracings

For joints with circular bracings use the above formulae but replace h_i and b_i with d_i and multiply resulting bracing effective width resistance by $\pi/4$ and use the relevant circular bracing factor.

6 LIST OF SYMBOLS

6.1 General alphabetic list – upper case

A_0, A_i, A_j	Cross sectional area of chord and bracing members, respectively
$A_{v,0}$	Chord shear area for gap K- and N-joints and is dependent upon the type of bracings and the size of the gap
E	Modulus of elasticity: $E = 210000 \text{ N/mm}^2$ (EN 1993-1-1:2006) $E = 205000 \text{ N/mm}^2$ (BS 5950-1:2000)
I	Moment of Inertia, about relevant axis
L	System length of member
$N_{eq,Rd}$	Joint axial design resistance in terms of axial force in equivalent bracing member
$N_{i,Ed}$	Factored (ultimate) applied axial force in bracing member
$N_{i,Rd}$	Joint design resistance in terms of axial force in bracing member
$N_{j,Rd}$	Joint design resistance in terms of axial force in overlapped bracing member j
$N_{1,Rd} \text{ (csw)}$	Joint axial design resistance in terms of axial force in bracing member 1, for chord side wall failure (chord side wall buckling or chord shear) at $\beta = 1.0$
$N_{1,Rd} \text{ (cfd)}$	Joint axial design resistance in terms of axial force in bracing member 1, for chord face deformation with $\beta = 0.85$
$N_{0,gap,Ed}$	Factored (ultimate) applied axial force in the chord, in the gap of a K-joint
$N_{0,gap,Rd}$	Joint axial design resistance in terms of axial force in the chord, in the gap between bracings of a K-joint
$N_{0,Ed}$	Factored (ultimate) axial force in chord
$N_{p,Ed}$	Factored (ultimate) axial force in chord excluding the effect of the horizontal brace force components
$N_{pl,0,Rd}$	Chord axial plastic design resistance, $N_{pl,0,Rd} = A_0 f_{y0} / \gamma_{M0}$
$M_{ip,0,Ed}, M_{ip,i,Ed}$	Factored (ultimate) applied moment in plane in chord and bracing members respectively
$M_{ip,i,Rd}$	Joint axial design resistance in terms of moment in plane in bracing member i
$M_{op,0,Ed}, M_{op,i,Ed}$	Factored (ultimate) applied moment out of plane in chord and bracing members respectively
$M_{op,i,Rd}$	Joint axial design resistance in terms of moment out of plane in bracing member
P_{eq}	Equivalent bracing footprint perimeter based on the perimeter of two bracings
P_i	Bracing footprint perimeter on a flat chord face (even for circular chord)
P_j	Bracing footprint perimeter for overlapped bracing
$V_{0,Ed}$	Factored (ultimate) shear force in the chord, in the gap of a K-joint
$V_{pl,0,Rd}$	Shear design resistance of the chord
$W_{el,ip,0}, W_{el,ip,i}$	Elastic modulus of chord and bracing members respectively, in the plane of the joint
$W_{el,op,0}, W_{el,op,i}$	Elastic modulus of chord and bracing members respectively, out of the plane of the joint
$W_{pl,ip,0}, W_{pl,ip,i}$	Plastic modulus of chord and bracing members respectively, in the plane of the joint
$W_{pl,op,0}, W_{pl,op,i}$	Plastic modulus of chord and bracing members respectively, out of the plane of the joint

6.2 General alphabetic list – lower case

a	Fillet weld throat thickness
b_0, b_i, b_j	Width of rectangular, I- or H-chord and bracing member, respectively, out of plane of the joint
$b_{e,ov}$	Effective bracing width, overlapping bracing to overlapped bracing, for rectangular bracing
$b_{e,p,i}$	Effective bracing width, for chord punching shear, for rectangular bracing
$b_{eff,i}$	Effective bracing width, bracing to chord, for rectangular bracing
b_{eq}	Equivalent bracing width
b_p	Width of reinforcement plate for rectangular chord, out of plane of the joint
$b_{w,i}$	Chord web effective width for I- or H-section chord
c_s	Coefficient for effective shear area of bracings depending if the overlapped bracing is welded or not
d_0, d_i, d_j	Diameter of chord and bracing members, respectively
$d_{eff,i}, d_{eff,j}$	Effective bracing width, bracing to chord, for circular bracing
d_{eq}	Equivalent bracing diameter
d_{min}, d_{max}	Equivalent bracing diameter, minimum and maximum respectively
d_w	Web depth of I- or H-section chord: $d_w = h_0 - 2(t_f + r)$
e	Joint eccentricity
exp	Exponent or natural antilogarithm, $\exp(x) = e^x$ where $e = 2.718281828$
f_b	Chord side wall buckling strength
f_{y0}, f_{y_i}, f_{y_j}	Nominal yield (design) strength of chord and bracing members, respectively
$f_{y0,r}$	Reduced nominal yield (design) strength of chord, used when d_0/t_0 validity limit exceeded
f_{yk}	Chord side wall crushing strength
f_{u_i}, f_{u_j}	Ultimate tensile strength of overlapping and overlapped bracing respectively. Refer to EN 1993-1-1:2005 (where $f_{u_i} = 510 \text{ N/mm}^2$ for S355H) or Local National Annex. In NA to EN 1993-1-1:2005 f_{u_i} should be obtained from product standard.
f_{yp}	Nominal yield (design) strength of reinforcement plate
g	Gap or overlap between bracings, measured at the chord face. Negative value for overlap
h_0, h_i, h_j	Height of rectangular chord and bracing members, respectively, in the plane of the joint
h_{eq}	Equivalent bracing height in the plane of the joint
k_g	Gap/lap factor
k_m	Chord stress factor for rectangular chord joints with a longitudinal gusset plate
k_n	Chord end stress factor for rectangular chord joints except longitudinal gusset plate joints
k_p	Chord stress factor for circular chord joints
l_p	Length of reinforcement plate

n	Most compressive applied factored (ultimate) stress ratio in the rectangular chord, adjacent to the joint and is negative for tension, $n = (\sigma_{0,Ed} / f_{y0})$
n_p	Least compressive applied factored (ultimate) stress ratio in the circular chord, adjacent to the joint and is negative for tension, $n_p = (\sigma_{p,Ed} / f_{y0})$
p_c	Compressive strength from BS 5950-1:2000, clause 4.7.5 for struts
$p_{eff,i}$	Bracing effective width for I- or H-section chord, over chord web ratio
r	Root radius of I- or H-section
t_0, t_i, t_j	Thickness of chord and bracing members, respectively
t_f	Thickness of I- or H-section chord flange
t_p	Thickness of reinforcement plate
t_w	Thickness of I- or H-section chord web
w_p	Arc width of reinforcement plate for circular chord, see figure 23

6.3 Greek list

α	Non-dimensional gap factor for the effectiveness of the chord face to carry shear in K- and N-joints with a gap
β	Mean bracing diameter or width to chord width ratio: - for T-, Y- and X-joints: $\frac{d_1}{d_0}$; $\frac{d_1}{b_0}$; $\frac{b_1}{b_0}$; $\frac{d_{eq}}{d_0}$ or $\frac{b_{eq}}{b_0}$ - for K- and N-joints: $\frac{d_1 + d_2}{2 d_0}$; $\frac{d_1 + d_2}{2 b_0}$ or $\frac{b_1 + b_2 + h_1 + h_2}{4 b_0}$ - for KT-joints: $\frac{d_1 + d_2 + d_3}{3 d_0}$; $\frac{d_1 + d_2 + d_3}{3 b_0}$ or $\frac{b_1 + b_2 + b_3 + h_1 + h_2 + h_3}{6 b_0}$
χ	Flexural buckling reduction factor for relevant buckling curve
γ	Chord diameter or width to double its thickness ratio: $\frac{d_0}{2t_0}$; $\frac{b_0}{2t_0}$ or $\frac{b_0}{2t_f}$
γ_{M0}	Partial safety factor for resistance of cross-sections, all classes. Refer to EN 1993-1-1:2005, where $\gamma_{M0} = 1.00$, or local National Annex. In NA to EN 1993-1-1:2005 $\gamma_{M0} = 1.00$
γ_{M5}	Partial safety factor for resistance of joints in hollow section lattice girders. Refer to EN 1993-1-8:2005, where $\gamma_{M5} = 1.00$, or local National Annex. In NA to EN 1993-1-8:2005 $\gamma_{M5} = 1.00$
η	Bracing member depth to chord diameter or width ratio: $\frac{h_i}{d_0}$; $\frac{h_i}{b_0}$ or $\frac{h_{eq}}{b_0}$
κ	Reduction factor for knee joint strength
κ_{90}	Reduction factor for knee joint strength at $\theta_0 = 90^\circ$
$\bar{\lambda}$	Non-dimensional slenderness from EN 1993-1-1:2005, clause 6.3.1.2
λ_{ov}	Percentage overlap, see figure 57 : - for circular bracings: $\lambda_{ov} = \frac{ g \sin \theta_i}{d_i} \times 100\%$ - for rectangular bracings: $\lambda_{ov} = \frac{ g \sin \theta_i}{h_i} \times 100\%$
μ	Multi-planar correction factor
π	Pi is the ratio of the circumference of a circle to its diameter and is 3.14159...
θ_i, θ_j	Angle between bracing member and the chord in degrees
$\sigma_{0,Ed}$	Most compressive applied factored stress in the rectangular chord, adjacent to the joint, due to axial forces and moments and is negative for tension
$\sigma_{p,Ed}$	Least compressive applied factored stress in the circular chord, adjacent to the joint, due to axial forces and moments and is negative for tension

6.4 Suffix list

0	Chord member
1	Compression bracing for joints with more than one bracing or the bracing for T-joints
2	Tension bracing for joints with more than one bracing
3	Central bracing on KT-joints
i	Overlapping bracing or to designate bracing 1, 2 or 3 in gap or KT-joints
j	Overlapped bracing for overlapped bracing joints
p	Reinforcement

6.5 Pictorial

Figure 56:

Joint geometric symbols

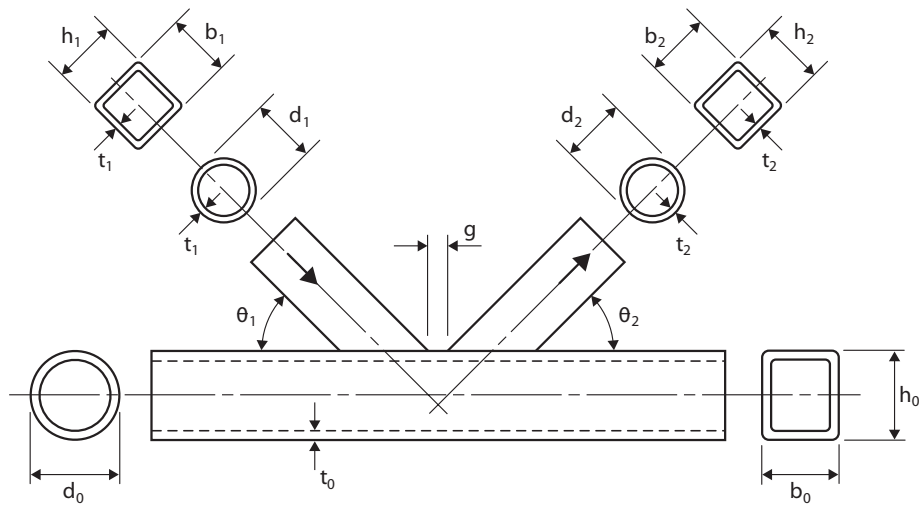

Circular and rectangular chord symbols

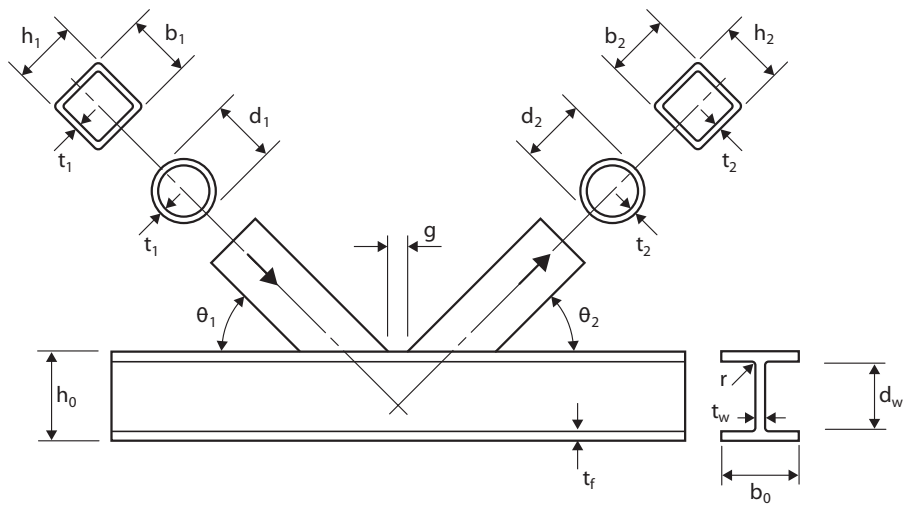

I- or H-chord symbols

Figure 57:

Definition of percentage overlap

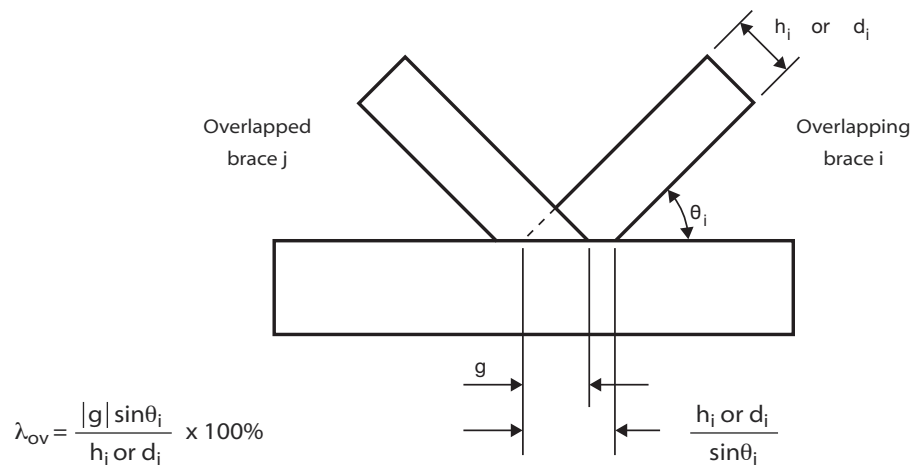
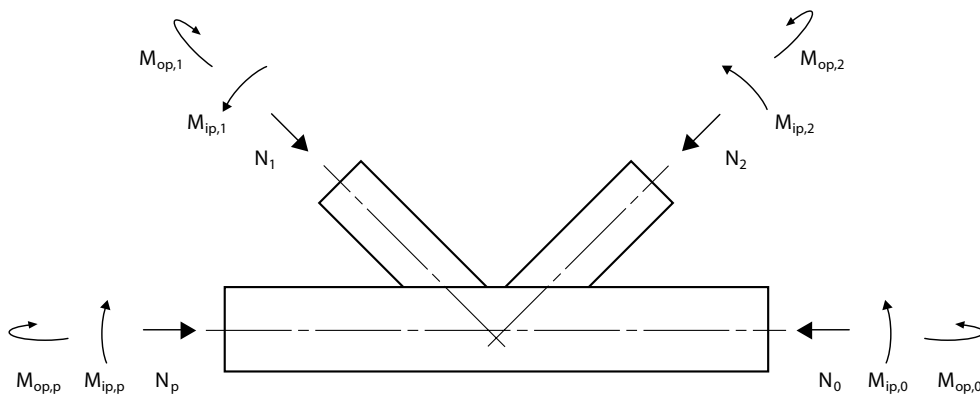

Figure 58:

Joint member force symbols



7 REFERENCES

7.1 Publications

- 1 CIDECT – ‘Design Guide for Circular Hollow Section (CHS) Joints under Predominantly Static Loading’, Verlag TUV Rheinland, Cologne, Germany, 1991, ISBN 3-88585-975-0. (1st Edition)
- 2 CIDECT – ‘Design Guide for Rectangular Hollow Section (RHS) Joints under Predominantly Static Loading’, Verlag TUV Rheinland, Cologne, Germany, 1992, ISBN 3-8249-0089-0. (1st Edition)
- 3 EN 1993-1-8: 2005 – Eurocode 3: Design of steel structures – Part 1-8: Design of joints
- 4 NA to EN 1993-1-8: UK National Annex to Eurocode 3 Design of steel structures Part 1-8: Design of joints
- 5 BS 5950-1: 2000 – Structural Use of Steelwork in Building – Part 1: Code of practice for design - Rolled and welded sections
- 6 EN 10025-2: 2004 – Hot rolled products of structural steels – Part 2: Technical delivery conditions for non-alloy structural steels
- 7 EN 10210-1: 2006 – Hot finished structural hollow sections of non-alloy and fine grain steels – Part 1: Technical delivery requirements
- 8 EN 10210-2: 2006 – Hot finished structural hollow sections of non-alloy and fine grain steels – Part 2: Tolerances, dimensions and sectional properties
- 9 EN 10219-1: 2006 – Cold formed welded structural hollow sections of non-alloy and fine grain steels – Part 1: Technical delivery requirements
- 10 EN 10219-2: 2006 – Cold formed welded structural hollow sections of non-alloy and fine grain steels – Part 2: Tolerances, dimensions and sectional properties
- 11 **Celsius® 355** Technical Guide
- 12 **Hybox® 355** Technical Guide
- 13 Advance™ sections
- 14 CIDECT – ‘Design Guide for Fabrication, Assembly and Erection of Hollow Section Structures’, Verlag TUV Rheinland, Cologne, Germany, 1998, ISBN 3-8249-0443-8
- 15 ‘The static design of stiffened and unstiffened CHS L-joints’ by Professor R.Puthli, Faculty of Civil Engineering, University of Karlsruhe, Germany – A paper presented at the ‘Tubular Structures IX’ conference, from a PhD Thesis by Mr D. Karcher (KLIB Ingenieur-Partnerschaft, Ottersweier, Germany)
- 16 Celsius Jumbo™ 355 Technical Guide
- 17 LCHS 355 Technical Guide

7.2 Useful websites

www.tatasteel.com
www.cidect.com

www.bsi-global.com
www.steel-sci.org
www.steelbiz.org
www.steelconstruction.org
www.iw-iis.org
www.twi.co.uk

Tata Steel
CIDECT – Comité International pour le Développement
et l'Étude de la Construction Tubulaire
British Standards Institute
SCI – The Steel Construction Institute
Steel Biz – Technical library for steel construction
BCSA – British Constructional Steelwork Association Ltd.
IIW – International Institute of Welding
TWI – The Welding Institute

www.tatasteel.com

While care has been taken to ensure that the information contained in this brochure is accurate, neither Tata Steel Europe Limited, nor its subsidiaries, accept responsibility or liability for errors or for information which is found to be misleading.

Copyright 2013
Tata Steel Europe Limited

Tata Steel

PO Box 101
Weldon Road
Corby
Northants
NN17 5UA
United Kingdom
T: +44 (0)1536 404561
F: +44 (0)1536 404111
marketing@tatasteel.com

English Language TST06:1500:UK:07/2013