

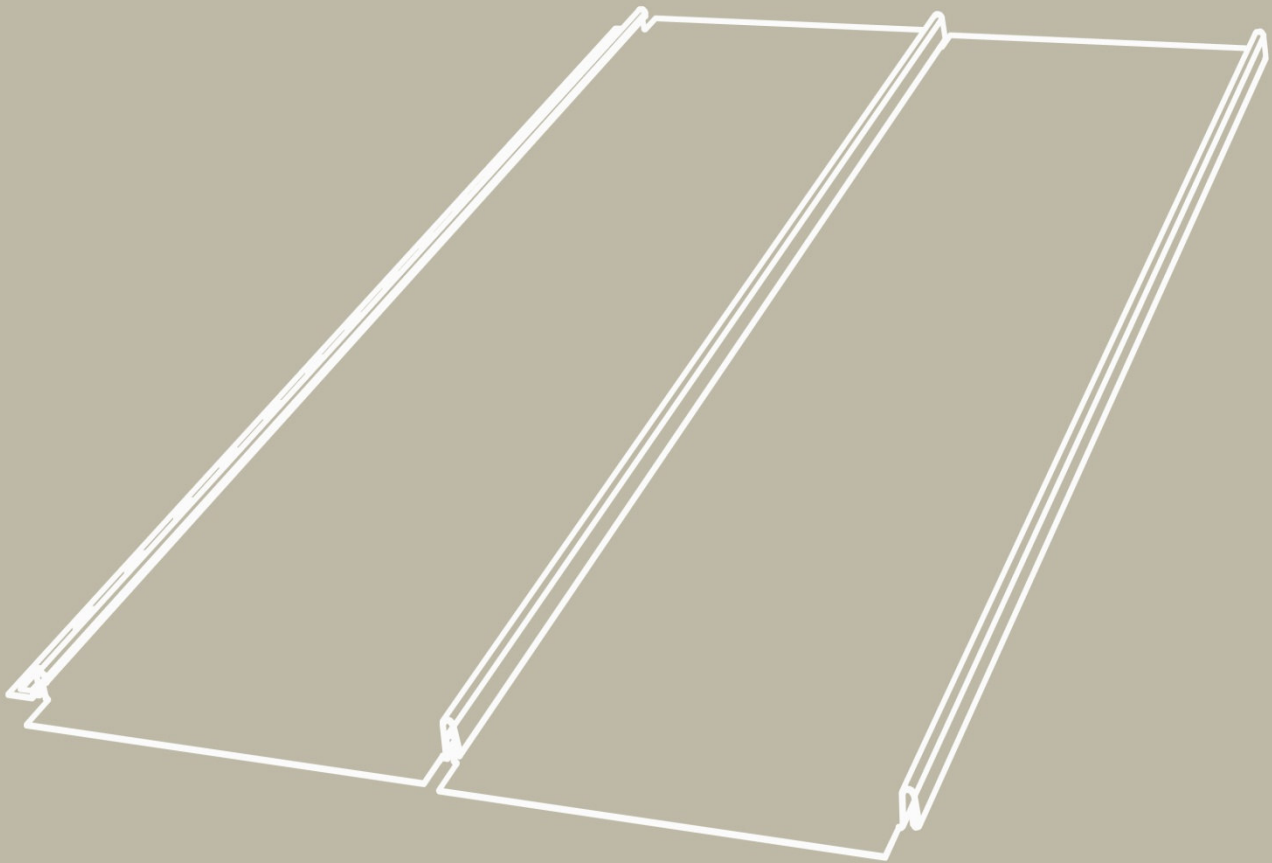

Colorcoat Urban®

Installation Guide

Tata Steel Colors



Contents

1.	Introduction	3
2.	Urban Profile	5
3.	Product Selector	6
4.	Colour Selector	9
5.	Ordering the roof	10
6.	Site Storage & Site practise	11
7.	Wind speed and fixing chart	12
8.	Setting out the roof	
8.1	Fitting Profile and Details	13
8.2	Urban Seam	15
8.3	Mono Ridge	17
8.4	Up verge	18
8.5	End Caps for Mono & Duo Pitch	19

Introduction

Tata Steel introduces a product that provides an innovative and sustainable solution for roofs and walls, specifically designed for the urban environment.

- Matt colour range specifically designed for the urban fabric.
- Stable colour ensures an aesthetic of consistent, even shade.
- Zero maintenance for up to 40 years.
- Can be laid vertically down to a pitch of 5°.
- Eco-designed to remove environmentally harmful elements and deliver the lowest impact without reducing the performance.
- 100% recyclable and Carbon Neutral, via a government approved carbon measuring, reducing and offsetting scheme.
- Simple integration of renewable technologies, helping achieve forthcoming legislation.

The Installation manual explains the details and techniques to install the Colorcoat Urban® roof. The approved roofing contractor installing the roof must closely follow this guide for the roof guarantee to apply.

Particular attention should be made of the fixing specification to ensure that the roof will meet the requirements of British Standards.

Urban Profile



Fixing

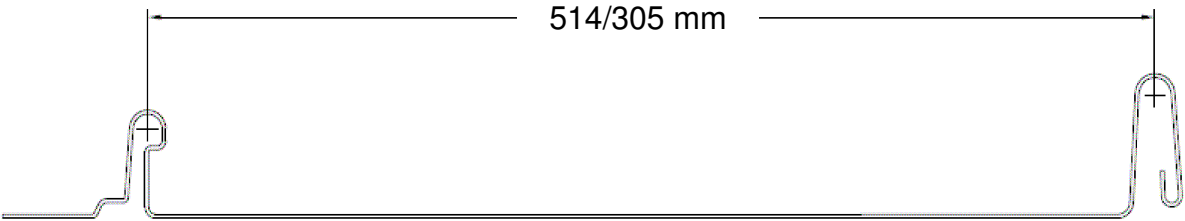
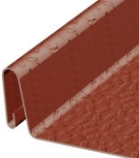
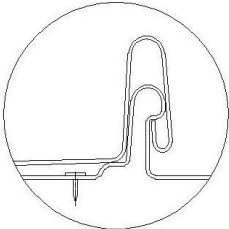

Product Selector

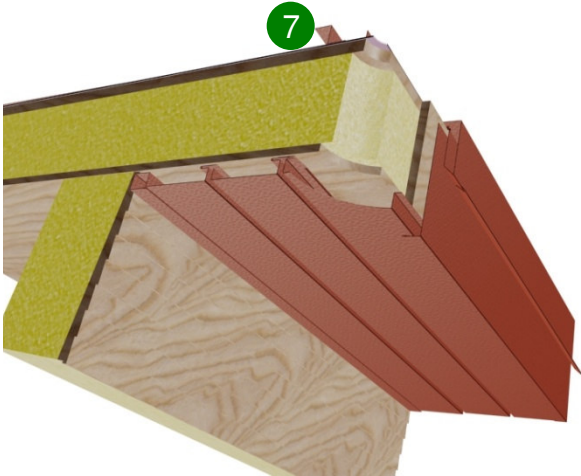
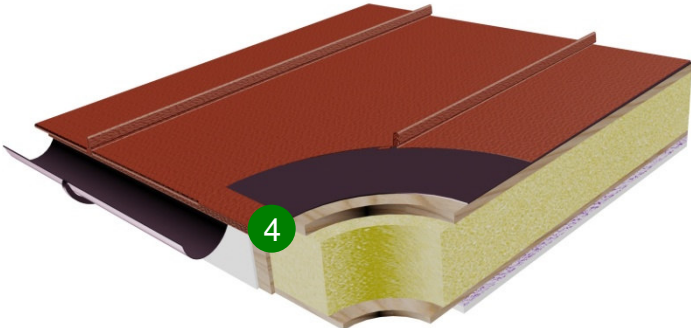
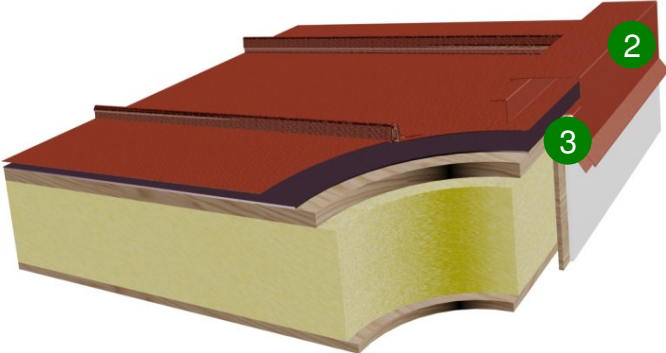
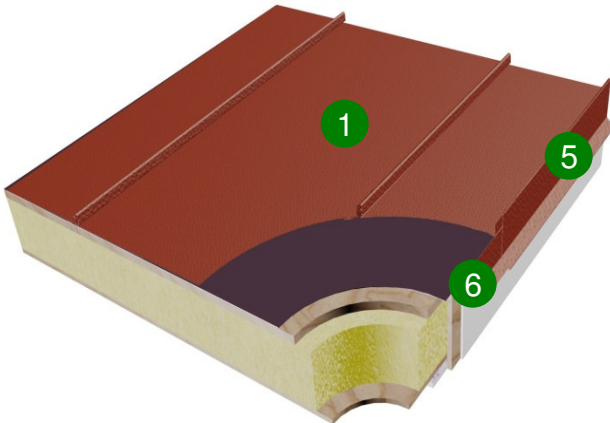

Product Selector

Product description	Reference code	Quantity	Detail No.
Urban Seam™ profile			
514 mm width	CU051400	m ²	1
305 mm width	CU030500	m ²	
Ridge Profiles*			
Mono Ridge	CU002400	3m	2
Mono Ridge Backing Plate	CU002500	3m	3
Stepped Ridge	CU004500	3m	
Standard Duo Ridge	CU004600	3m	
Large Duo Ridge	CU004700	3m	
Mono Ridge End Caps			
Left Hand	CU012700	1	
Right Hand	CU022700	1	
Duo Pitch Ridge End Caps			
Stepped Ridge	CU014500	1	
Standard Duo Ridge	CU014600	1	
Large Duo Ridge	CU024700	1	
Eave Detail	CU003600	3m	4
Verge Detail			
Verge	CU002700	3m	5
Verge Backing Plate	CU002800	3m	6
Z bar	CU004000	3m	7
Z bar	CU004100	0.5m	

00 – last two figures denote colour code

* Contractor to specify roof pitch

Product Selector

Product description	Reference code	Quantity	Detail No.
Fixings			
3.5 x 38 mm ring pin nails	CU020100	1000	
3.5 x 19 mm Pan Head	CU020200	1000	
Stainless Steel Screw			
Colour Matched Pot rivets, Aluminium / Stainless shaft 4.8 x 15 mm	CU020300	100	
Colour matched stainless steel low profile head 5.5 x 35 mm	CU020400	100	
Ancillary products			
Touch up paint with brush	CU030100	250ml	
Coloured Sealant Black	CU030201	300cc	
Coloured Sealant Grey	CU030202	300cc	
Coloured Sealant Red	CU030203	300cc	
Coloured Sealant White	CU030204	300cc	
Filler Block 510 x 30 x 30 mm	CU030300	Pack of 10	

Colour choice

The naturally inspired colour range can blend with the urban landscape, ensuring the building harmoniously integrates with the local vernacular.

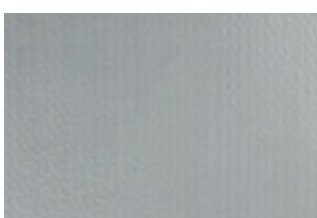

Winter Sky 01
RAL 7040



Alaska 02
RAL 7000

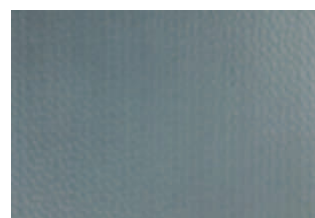

Merlin 03
BS 18B25

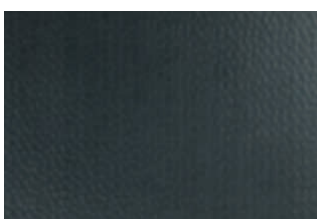

Anthracite 04
RAL 7016

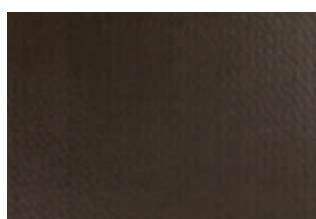

Oxidised 07
RAL 8014 or 0502010



Terracotta 05
BS 04C39

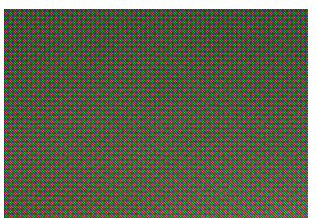

Green Grey 06
RAL 6003 or 1504010



Patina 08
RAL 6027 or 1807025

Urban fabric

The Colorcoat Urban® colour range has been inspired by architects specifically for the urban environment.

As such they partner harmoniously with existing buildings and building envelope materials, including glass, wood, brick, stone and render.

Matt shades

The tonal colour range of the matt shades have been carefully selected. With the ability to achieve a stable colour ensures a consistency of even colour, which is unachievable from most other roofing materials.

Note:

Hand sample requests are available online at www.colorcoaturban.com or via Colorcoat Urban helpline on +44 (0) 1244 892449.

Ordering the Roof

Essential points

Tata Steel manufactures the roof based on measurements provided by the customer.

These details can be found on the drawing produced by the roof truss or SIP panel manufacturer.

The maximum panel length is 12.5 metres

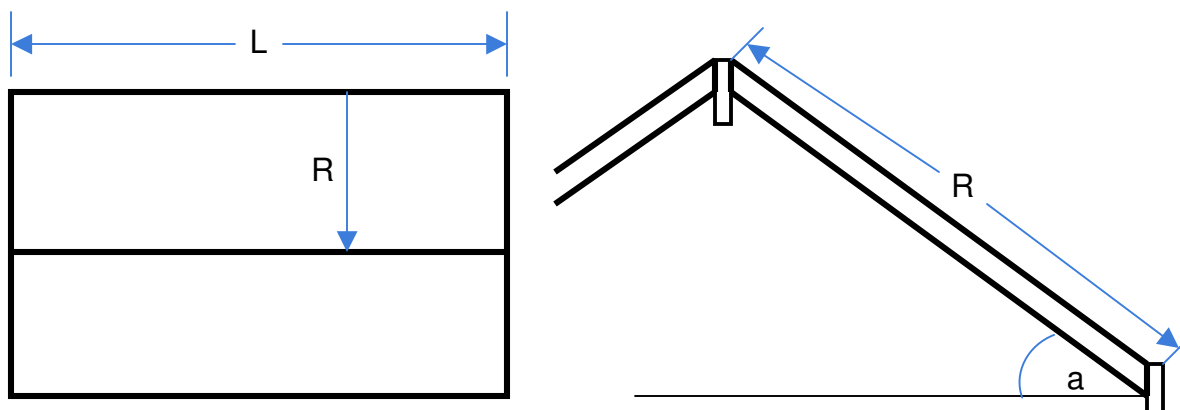

Estimating straight roofs

For the straight roof we need four details: length (L), rafter length including fascia board (R), angle of pitch (a) and whether it is mono or duo pitch roof.

Estimating For roofs with Hips and Valleys

Tata Steel has software to estimate and create the bill of materials for roofs with hips and valleys. The software takes advantage of nesting that allows panels to be cross cut to improve yields.

Estimating fixings

For the Urban Seam® profile at 514mm wide you will need a minimum 10 fixings per square metre. When securing the eaves, verges & mono ridge backing plates, 6 fixings per linear metre. To secure the ridge Z bar, 16 fixings per linear meter for the duo pitch and 8 for the mono pitch. If using colour coded screws or rivets for securing ridge to the z bar then the spacing is every 500 mm.

Panel Lengths

The panel maximum length (R) is 12.5 metres, this is due to the thermal expansion of the pan. How to deal with roof over 12.5 metres is to create a change in fall in the roof, for example a mansard or join panels.

Site Storage & Site Practise

Essential points

- Check that all components ordered are delivered
- For any discrepancies between the order and delivery please contact Colorcoat Urban as soon as possible

Storage and handling

If sheets are handled and stored with care, then in use they can have a life of many years. A number of steps should be taken to avoid such a situation:

The site supervisor should immediately inform the supplier of any missing or damaged sheets. Sheets in bulk should be handled using a lifting beam in conjunction with suitable slings and spreaders, or a fork-lift truck with appropriate fork dimensions.



Long sheets should be lifted using a suitable long lifting beam. If storage indoors is not possible, protect the sheets – particularly opened packs – with a waterproof covering, which should be supported on a scaffolding frame, leaving sufficient room on all sides for air to circulate.

Once packed and wrapped, packs are stored internally and loaded directly onto trailers ready for despatch. Each and every trailer undergoes a thorough inspection before being signed off for delivery.

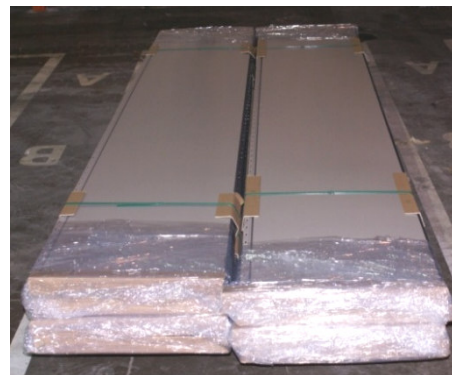

Alignment and tolerance of the work structure of the building should be checked to ensure it is within the specification given. If it is not, panels may not fit correctly.

Site Storage & Site Practise

Store the sheets off the ground on timber bearers which should be spaced no more than 900mm apart. Incline the stacks so that any rain which penetrates the covering will drain off. If stacked or bundled products do become wet, then separate them and wipe them dry with a clean cloth. Inspect the sheets at regular intervals to check for any leaks in the covering.

Sheets should be handled carefully to avoid damage. Do not drag materials over rough surfaces or fixed sheets. Do not drag tools over sheets, and protect from swarf (metal debris).

When carrying by hand, use appropriate Personal protective Equipment (PPE) and carefully lift and turn sheets and carry them on their edge.

Wherever possible, lift single sheets manually onto the roof. If a sheet has to be hoisted into position, make sure that its edges are protected and that pressure across the sheet does not distort it. Use only ropes or slings for hoisting, never chains.

When working on a roof, wear only soft-soled shoes. Before accessing the roof check the soles of your shoes are free from screws, nails and stones.

Cutting

For cut-outs, opening and cuts that are not straight use a Jigsaw or reciprocating saw. For longer straight cuts we would recommend a circular saw producing a 'cold' cut using a fine tooth metal cutting blade (i.e. not a grinding blade, which would damage the coating). All panel or fabrication cutting must be completed away from the roof to eliminated the risk of transferring swarf onto the roof panels. All exposed panel edges should be deburred and protected with a touch-up paint.

Wind Speed and Fixing Chart

Essential points

- For all buildings between 1 – 8 stores at a pitch 5° - 45°
- Please refer to the following specification

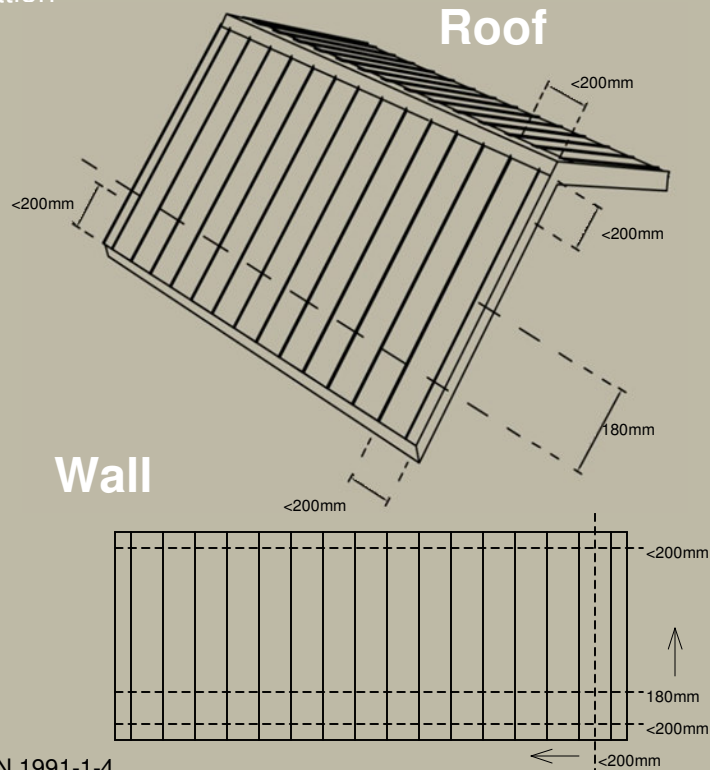

- In accordance with BS 6339-2 and BS5534 & BS EN 1991-1-4 Section 7.2.5
- Specification of the 514mm/305mm wide panel is dependant location, wall height, storey height and roof pitch.*A structural engineer should complete a wind uplift calculation for your specific area before making any final decision. Please note table below is for guidance only;

Roof Pitch (Degree) & Wall	No. Storeys	Wind Speed V_s	Panel Width 305mm	Panel Width 514mm
(5-9)	<3	≥ 25	✓	X
	4-8		✓	X
(5-9)	<3	<25	✓	✓
	4-8		✓	X
≥ 10	<3	≥ 25	✓	✓
	4-8		✓	X
≥ 10	<3	<25	✓	✓
	4-8		✓	✓

- When Building over 3 storey or in exposed locations the structural engineer should complete a wind uplift calculation and provide Tata Steel with details so the best fixing solutions can be developed.
- Please follow our recommendations for fixing the Urban Seam® profile as described.
- Fixings along the eaves, verge and Mono Ridge backing plates require fitting at 200mm fixing centres. Same principle applies to wall.
- Fixings into the panel nailing strip must be at 180mm centres.
- For detailed nailing patterns please refer to fixing of Urban Seam profile section in the installation guide.
- Urban Seam® profile is fixed to 18mm OSB 3, WBP or Marine Ply board. (15mm board is used for SIP panels) For other board types or dimensions please contact our technical advice line.
- For any advise and technical assistance in regards to wind speed or fixing positions please e-mail or contact our technical advise on Colourcoaturban@tatasteel.com

Setting out the Roof

Essential points

- The installer needs to check the squareness and the dimensions of the roof against the drawings supplied and to compensate for any differences.
- The roof dimensions to be checked at the ridge, eaves and the verges front and back.
- The eave, verge and ridge backing plates (for mono pitch) need to be installed before laying the pans

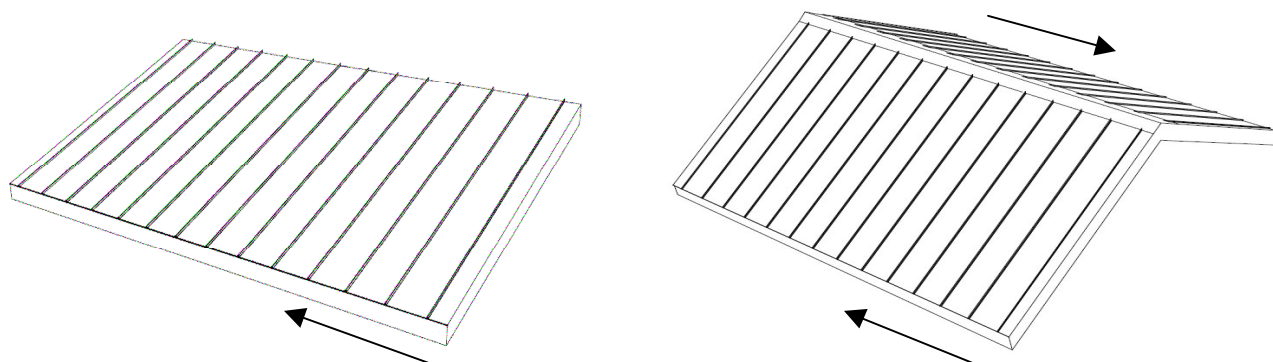

Mono Ridge

It is essential to check the squareness and the dimensions of the roof.

The roof system allows for an adjustment of up to 40mm at the ridge and 10 mm at the eave, so on length of the profile there is up to 50mm of adjustment. There is a further 15mm of adjust on each of the verges.

The adjustment at the eave, ridge and verge are explained in the relevant sections.

The arrow denotes laying direction, which is right to left although panels may be installed left to right . Before the first profile is laid the eave plate and the backing plates for the verge and the ridge need to be fitted.

Duo Ridge

As with the Mono pitch, it is essential to check the squareness and the dimensions of the roof.

The roof system again allows for an adjustment, however for the classic duo ridge the adjustment is up to 30mm at the ridge, (for the Stepped and the Large duo ridge cap it is 40mm) and 10 mm at the eave, so on length of the profile there is up to 50mm of adjustment.

There is a further 15 mm of adjust on each of the verges giving a maximum +/- adjustment on width of 30 mm from the drawing, without the need of cutting a profile onsite.

The adjustment at the eave, ridge and verge are explained in the relevant sections.

The arrows denotes laying direction, which is right to left on the front and back, although panels may be installed left to right . Before the first pan is laid the eave plate and the backing plate for the verge has to be fitted.

Urban Seam® - CU051400 / 030500

Essential points

- The standing seam panel is generally laid from right to left, locate starter the panel with the upturned edge and with the “nailstrip” on the left.
- The eave plate, ridge backing plate (mono pitch only) and the right hand verge backing plate should all be in place and square.
- Ensure the roof dimensions and drawing dimensions correspond to the panels lengths & roof cover width.
- When fastening down the Urban Seam®, the screws or nails should be centred in the slot and not over tightened to allow the for panel expansion



Fitting the Urban Seam Profiles

Check the drawings to ensure the roof and the profiled panels are sized correctly. In the ridge description this explains how tolerance can be taken up.

Using folding tool turn the front drip edge of the profile down so that it latches over eave profile.

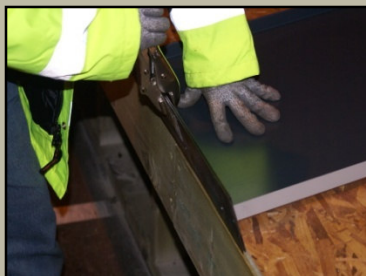

The back of the profile needs to be turned up to prevent rain water being pushed up beyond the top of the panel. The corners require sealing as described in the instructions for fixing the ridge details.

When installing panels to roofs less than 15° apply two continuous beads of sealant across the eaves plate before installing the urban panels



The Urban Seam® edge profile is the placed over the edge detail backing plate and the folded drip edge over eave detail. As the backing plate should have been made square the verge backing plate can be used as the line for the pan. It is important to re-check that the pan is lined up correctly before fastening down. The pan can either be fastened down with specified nails or screws. Screws can be used in limited applications. Please contact our technical team for advice

When fastening down the Urban Seam® the screws or nails should be centred in the slot and not over tightened. This will allow for panel expansion. For detailed information please follow Work Instruction QPCCUINSTALLATION02

Urban Seam®- CU051400 / 030500

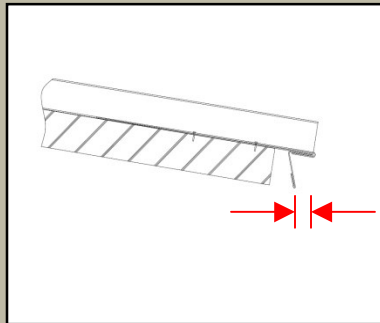
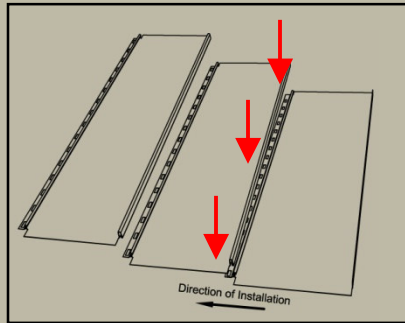

After the right hand edge panel is fitted the next panel is clipped onto the first panel. Ensuring the edge of the up-stand are aligned with first panel.

The installer should also ensure that the cover width is maintained. On hot days the panel may have expanded to minimise this the panel should not be left in the sun prior to fitting.

On very cold days the profiles may have contracted. The pans may need stretching to ensure the cover width of 514 mm or 305 mm this achieved by pulling the pan against the clipped edge before nailing.

Once the penultimate panel is fitted then the left hand side eave backing plate can be fitted to compensate for any minor discrepancies. The left hand side panel can then be fitted on top and the verge detail can be fitted as described in the section explaining how to fit the verge.

Another consideration when fitting on very hot days is that when the weather cools the steel will contract. The expansion point for the roof system is the eave.

The sheet may contract back at the eave. It is therefore important not to push the folded edge of the panel hard against the eave profile.

For detailed information please follow Work Instruction QPCCUINSTALLATION02

Using either the seamer tongs or the Rau drip edge seamer to fold over the edge of the profile tight against the eave detail.

Mono Ridge CU002400

Essential points

- Check the drawing of the roof and also measure across the ridge
- For any discrepancies in the length of the roof please adjust by offsetting the mono backing plate by 10mm away from the edge of the board before fixing into position

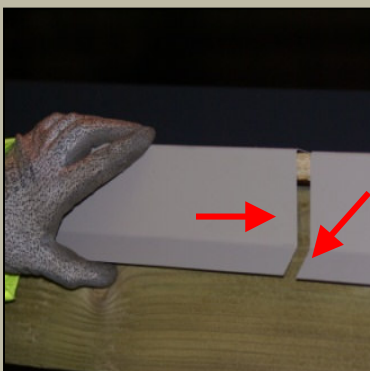

Butt up all Mono backing plates end to end. Snip down the last one to fit.

For any adjustment, pull out the backing plate out as required.

The mono backing plate has been designed so that the installer has some adjustment if required.

If the tolerance is required then ensure that all backing plates line up.

Secure the backing plate along the length of the ridge using 200mm fixing centres
For detailed information please follow Work Instruction QPCCUINSTALLATION01

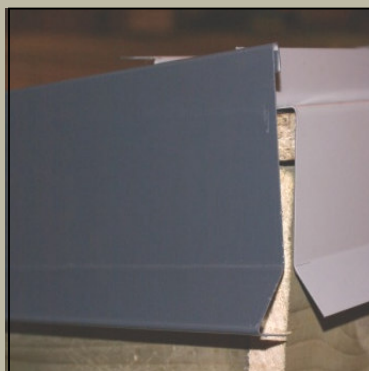

Ensure that the edge of the Mono Ridge backing plate is in line with the end of the Verge detail.

For several backing plates ensure that the length is divided equally along the whole length of the ridge to have a equal length of end piece at both left and right ends.

Please follow our recommendations for fixing the Urban Seam® profile

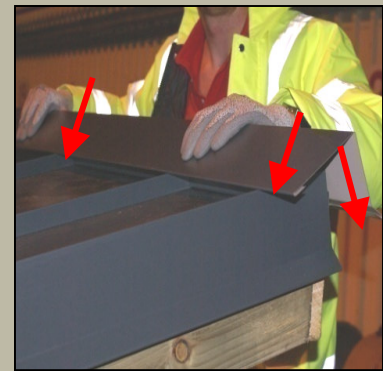

Before securing the Z bars, position the bar on top of the panel, between the seams. Locate the mono ridge plate into the Z bar open welt. Locate the bottom flange of the mono ridge plate over the packing plate. Ensure the Z bar is positioned so it allows the bottom flange of the ridge plate to be clipped over the backing plate and the Z bar is sufficiently located into the ridge plate open welt.
10mm Min

This should be completed to both ends and the middle of the roof.

Ensure that the ridge plate can be positioned to both the Z bar and backing plate along the full length of the roof

Then using a alignment wire. String the wire along the whole span of the roof from edge to edge.

This will locate the fixing position of all additional Z bars.

Mono Ridge CU002400



Apply 2 x continuous beads of sealant to the underside of the Z Bar before fixing into position.

Also a strip of sealant is recommended up each back fold on each side of all the individual pans.

Ensure all gaps and possible cavities are sealed using the sealant gun.

This will help prevent any ingress getting behind the Z bars and up folds of the Urban Seam pans.

Seal along the top of the seam between the foam fillers as noted with the blue arrow.

Secure the Z bar using 4 fasteners equally spaced across the panel. (200mm Min)
All fasteners must be located behind the sealant

For detailed information please follow Work Instruction QPCCUINSTALLATION03



After sealing all the required areas.

A strip of sealant is recommended to be placed directly behind the z bar to secure the foam filler block in place.

A foam filler block is required to be placed directly behind the Z bar and the correct compression is achieved.

A foam filler block is recommended in behind each Z bar spanning the ridge.

The foam filler block should also be located right up to the verge in the last pan at each edge.

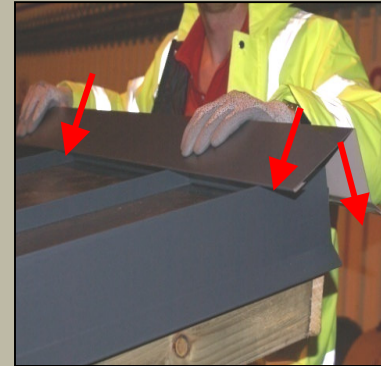

Position the mono ridge open welt onto the leading edge of the Z Bar. Ensure the leading edge of the Z bar is positioned correctly along the full length of the ridge before pushing down to locate onto the bottom of the ridge backing plate.

When additional ridges are required to cover the width of the roof, a butt strap or overlap technique must be used. Two continuous beads of silicone must be applied across each side of the ridge or butt strap. One of the beads must be applied 1–2 mm from the edge of the ridge. The Ridge can then be either seated on top of the butt strap or slid over the previous ridge if overlapping. The joint must then be secured into position using colour coded rivets

Ensure an overlap of (10–15mm) to secure the end cap at each end. See End Cap detail.

Crimp along bottom edge of the Mono Ridge capping piece to secure in place.

Up Verge CU002700

Essential points

- Check the drawing of the roof and measure across the top, middle and bottom of the roof to confirm all dimensions are correct
- For any discrepancies in the length of the roof please adjust by offsetting the verge backing plate by an extra 10mm away from the edge of the board before fixing into position



The Verge backing plate needs to be placed on top of the breathable membrane.

Butt up all Verge backing plates end to end. This will help in ensuring the roof is square. Snip down last one to fit.

Ensure that the edge of the verge backing plate is in line with the end of the eave detail and also square.

For any adjustment, pull out the backing plate out as required.

Please follow our recommendations for fixing the Urban Seam® profile



Locate the open welt of the verge fascia over the flange / upturn of the start / end panel. Using a rubber mallet, hammer the verge welt down onto the panel flange, this will allow the bottom of the verge fascia to clip over the bottom of the backing plate. Ensure the ends of the verge fascia are flush with the eave and ridge backing plate

When additional verge plates are required to cover the length of the roof, a butt strap should be installed. The verge is then seated on top of the butt strap and secured into position using colour coded rivets (When jointing the verge fascia, ensure the joint is not positioned at the same location as the backing plate) Using a Stubai Pliers, crimp along the bottom edge of the verge to secure to the backing plate



Crimp along the bottom of the verge and the top to secure the Verge in place.

If the verge still has movement then crimp tighter to ensure it is secured in place.

Install pop rivets at both the eave, joints & ridge ends of the verge

For detailed information please follow Work Instruction QPCCUINSTALLATION01

Ventilated Duo Ridge CU004800

Essential points

- What type of roof space is it Warm or Cold
- Check the measurement across the ridge

According to BS 5250 a warm roof is a roof that the warm moist air from the inside does not meet the cold air from the outside. All other roof types require ventilation. The detail below shows ventilation requirements dependant on the roof type & pitch.

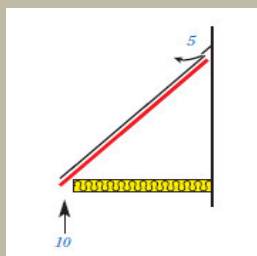
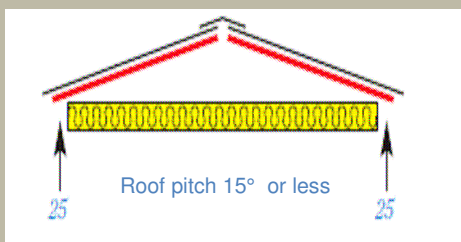
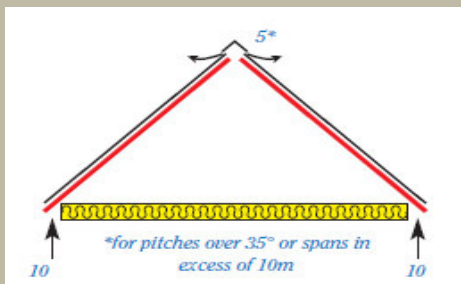
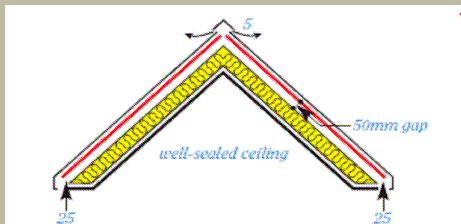
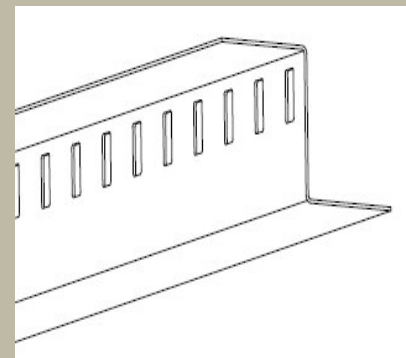

Using a small sample of ridge establish the fixing position for the Z bar. Ensure the Z bar is positioned so it allows each side of the ridge plate open welt to be located into the leading edge of the z bar. Min 10mm This should be completed at the start, end and centre of the roof. Once these positions have been established, string line a mark across the width of the roof.

When installing vented Z bars that are factory notched measure the distance between the starter panel upturn and seam. Cut the end of the notched Z bar to length and snip all retaining material at the rear of each notch. Apply 2 x continuous beads of sealant to the underside of the Z Bar & locate the Z Bar onto the roof panel and fix in position using 4 fasteners equally spaced across the panel. (200mm Min) Apply sealant around the perimeter of the Z bar notch and panel seams. If excess sealant is not visible at front of the Z bar, additional sealant can be applied using the cartridge

For further information relating to installation of vented Z bars to roofs lower than 15° please contact Tata Colorcoat Urban Technical department.

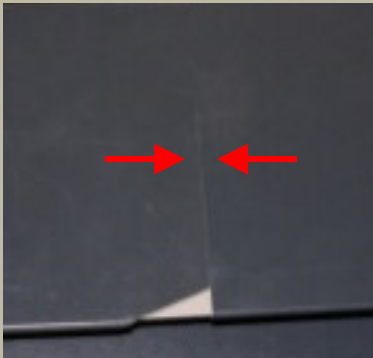

When additional ridges are required to cover the width of the roof, a butt strap or overlap technique can be used.

Two continuous beads of silicone must be applied across each side of the ridge or butt strap. One of the beads must be applied 1–2 mm from the edge of the ridge. To secure the ridge to the Z bar, install colour coded rivets through the ridge and into the Z bar. Ensure the rivets are positioned behind the sealant. Caution must be taken not to damage the roof panels when drilling holes for the rivets

For detailed information please follow Work Instruction QPCCUINSTALLATION03

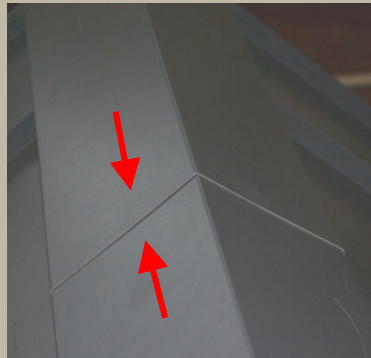

The Ridge can then be either seated on top of the butt strap or slid over the previous ridge if overlapping. The joint must then be secured into position using colour coded rivets

This process will need to be replicated for each additional ridge, along the length.



The ridge should extend past the verge by approx 20mm so there is sufficient area for the end cap to be secured

Once the ridge is secure install the end caps. Apply sealant to each edge of the end cap and Locate under the ridge plate. Secure in position using colour coded rivets.

When installing off set ridges, the verge must be fabricated to form the end cap. Ensure the interface between the verge & ridge is sufficiently sealed.

End Cap for Mono & Duo Ridge

Essential points

- Check that the overlap of the ridge is sufficient for the end cap to fix into
- Ensure that the angle of the end caps has been produced for the pitch of the roof

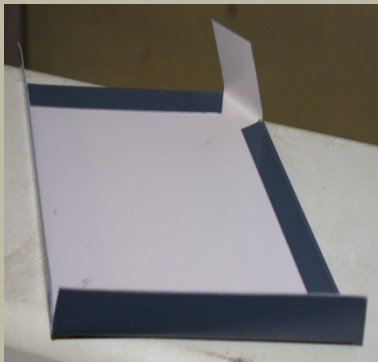

Installing the end caps

The end cap will be required for both Mono and Duo pitch roofs .

Ensure there's sufficient material to fix the end cap securely into place.

The Duo and Mono cap ridges will be made for different roof pitch.



Apply sealant to each edge of the end cap flange and locate under the ridge plate. Secure in position using colour coded rivets.



The ridge should extend past the verge by approx 20mm so there is sufficient area for the end cap to be secured.

Crimp over the bottom tab of the end cap.

www.colorcoaturban.com

Trademarks of Tata Steel

Colorcoat, Colorcoat Connection and Colorcoat Urban are trademarks of Tata Steel.

Corus is part of the Tata Steel group.

Care has been taken to ensure that the contents of this publication are accurate, but Tata Steel UK Limited and its subsidiaries do not accept responsibility or liability for errors or information that is found to be misleading. Suggestions for, or descriptions of, the end use or application of products or methods of working are for information only and Tata Steel UK Limited and its subsidiaries accept no liability in respect thereof.

Before using products supplied or manufactured by Tata Steel UK Limited and its subsidiaries, customers should satisfy themselves as to their suitability.

Printed on material which is manufactured from ECF (Elemental Chlorine free) pulp sourced from certified or well managed forests and plantations.

Inks used are vegetable based.

Copyright 2008 Tata Steel

Sales Contact Details

Tata Colorcoat Urban

Shotton Works

Deeside

Flintshire CH5 2NH

United Kingdom

T: +44 (0)1244 892449

F: +44 (0)1244 892442

E: colorcoaturban@tatasteel.com

W: **www.colorcoaturban.com**

Language English 0708