

Abspoel & Scholting Forming Limit Curve

A fast and easy prediction method with improved accuracy

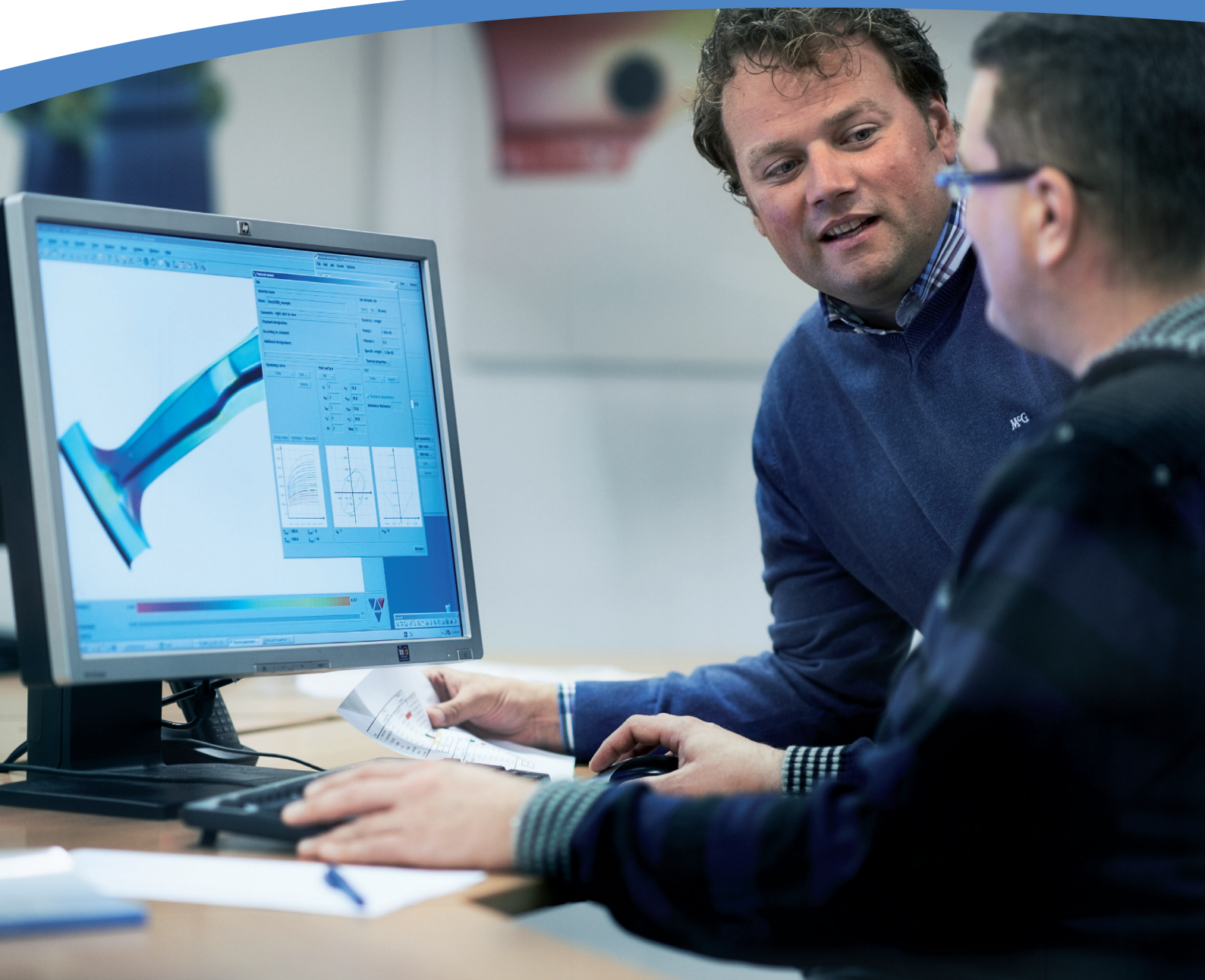

Tata Steel developed a prediction method for Forming Limit Curves (FLC), improving the accuracy of the FLC. Based on tensile test data the method determines FLCs fast and easily.

A FLC is a line representing major and minor strain combinations at which the material fails (figure 1). FLCs are very often used in press shops and for finite element (FE) analysis to assess press part safety. As Tata Steel we support these activities by distributing material data like FLCs for our products via our online materials database Aurora Online to our customers. Figure 2 shows on the left a pressed part, on the right the strain distribution of the formed part is shown and at the bottom the same strain is shown as major/minor strains.

Aurora® Online offers a complete overview of the steel grades supplied to the automotive industry by Tata Steel. This cutting-edge online database contains comprehensive up-to-date material files, data sheets and ready-to-run input decks. Aurora Online enables customers to set up accurate, reliable simulations. A direct link between the steel mill and database provides precise information representing the actual material properties required for validating processes.

Figure 1: FLC definitions

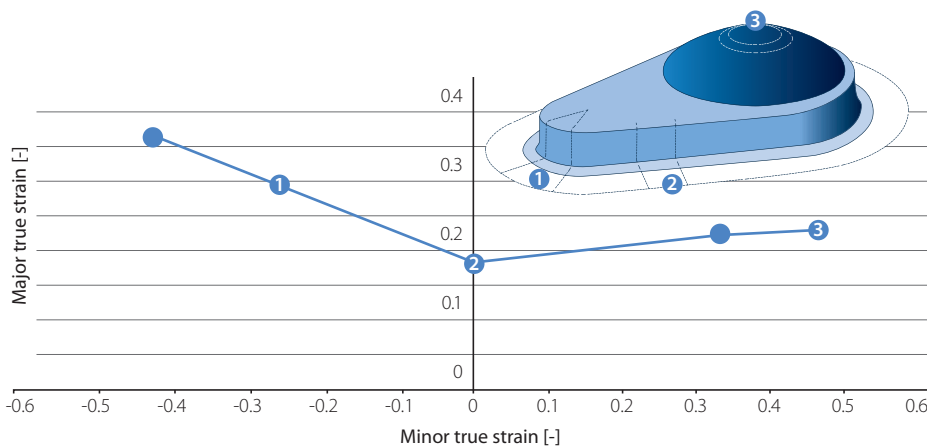

Figure 2: Measured strains in a pressed part compared to a FLC

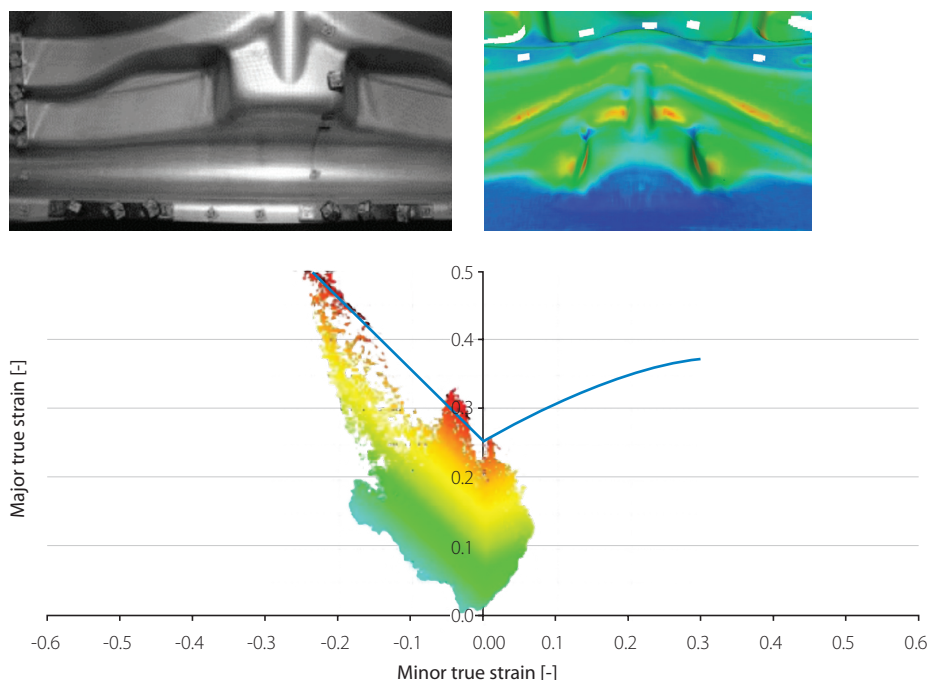
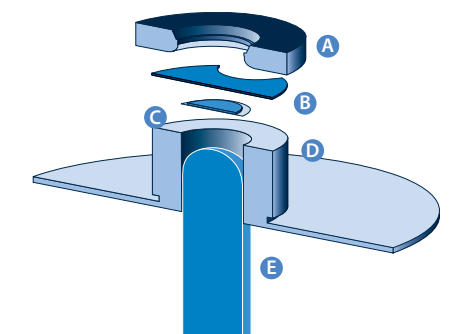

Figure 3: Nakajima hemispherical punch test



Key

- A Serrated Die
- B Sample
- C Tribo-system
- D Blankholder
- E Punch

Figure 4: Nakajima test versus Marciniak test

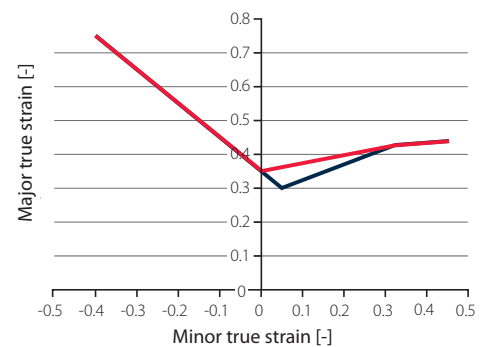

Key

- Marciniak FLC
- Nakajima FLC

Experimental versus empirical

For more than 50 years, FLCs are obtained through a series of experimental tests, either using the Nakajima test (hemispherical punch) or the Marciniak test (flat punch). At Tata Steel we use the Nakajima test (figure 3); to obtain a FLC for one material and one thickness, we need to measure 7 different sample shapes representing different strain distributions. Although time consuming, this test is mandatory to demonstrate the quality of the material in forming operations. For a long time, people have tried to capture the FLC through empirical equations. Although some empirical equations (e.g. the Keeler relation) have become popular in the last years, its validity for advanced and ultra high-strength steels is questionable. This is because they are either not intended for these kinds of steel, or they are not taking into account the different slope of the left side of the FLC due to strain ratio influence.

Figure 5: Cold-rolled forming steel - DC04

$t=1.0\text{mm}$, $A_{80}=44\%$, $r=2.38$

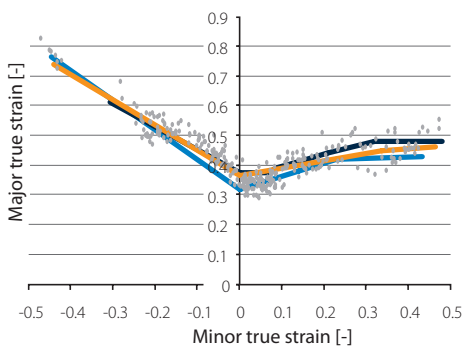

Key

- Datapoints
- Abspoel & Scholting
- Keeler
- Cayssials

Figure 6: Cold-rolled advanced high-strength steel - HCT600X+Z

$t=1.5\text{mm}$, $A_{80}=20\%$, $r=1.00$

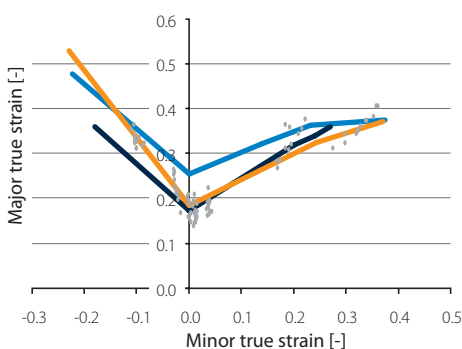

Key

- Datapoints
- Abspoel & Scholting
- Keeler
- Cayssials

Abspoel & Scholting FLC

Thanks to the availability of advanced real time strain measurement systems, it now is possible to investigate local strains in tensile tests and to identify the differences between two experimental FLC test methods (in figure 4 the Nakajima test is displayed in dark blue and Marciniak test in red). This has led to a good understanding of the bi-axial pre-strain artefact in the Nakajima test method and it gave information of the FLC at the left hand side, which is important for deep drawing.

A large amount of measured tensile and FLC data was used to create the empirical equations. The Abspoel & Scholting FLC is described with the total elongation (A_{80}) and plastic strain ratio (r-value) of a standard tensile test and the sheet thickness (t).

Figure 7: Hot-rolled forming steel - DD13

$t=2.1\text{mm}$, $A_{80}=42\%$, $r=0.95$

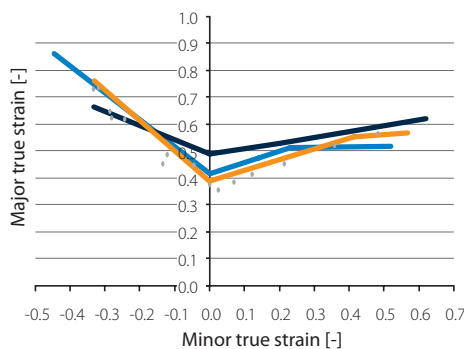

Key

- Datapoints
- Abspoel & Scholting
- Keeler
- Cayssials

Figure 8: Hot-rolled high-strength low-alloy steel - S420MC

$t=2.0\text{mm}$, $A_{80}=20\%$, $r=0.95$

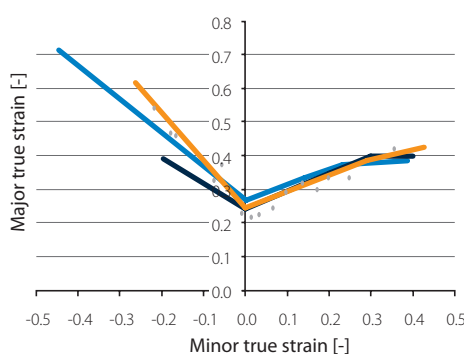

Key

- Datapoints
- Abspoel & Scholting
- Keeler
- Cayssials

These three properties are measured for each coil separately. Although the empirical equations are based on steel, the predictive method also works for aluminium, stainless steel and next generation steels. The developed equations are validated against the measured Nakajima, Marciniak and tensile specimens for almost fifty steel grades and also compared with other predictive methods (such as Keeler/Cayssials) that are implemented into commercial forming simulation software. In figures 5-8 some examples of the validation are shown.

Benefits

From the previous graphs, it can be clearly concluded that the Abspoel & Scholting FLC offers a more accurate representation of the measured FLC points than the currently used FLC prediction methods. The accuracy of the customer simulations directly benefit from this accurate representation. Also, the absence of bi-axial pre-straining will further improve the predictability of the simulations.

Another big advantage of the prediction method is that the Abspoel & Scholting FLCs will always be available: where in the past the availability of a FLC depended on execution of forming limit tests, today we need a tensile test only to determine the FLC. This also implies that Tata Steel has FLCs available for all steel grades and all thickness ranges.

Furthermore we can speed up the vehicle development process, since there is no longer a need to wait for FLC testing. FE analysis to assess press part safety can be started early in the development of a new grade which makes the introduction of new materials inside car manufacturers easier.

Availability

The details of the Abspoel & Scholting FLC are published in the Journal of Materials Processing Technology, Volume 213, Issue 5, May 2013, Pages 759-769. The Abspoel & Scholting FLC is used to fill our online material database Aurora Online is also implemented in several commercial FE stamping software.

Our experts are there to support the deployment of the Abspoel & Scholting FLC for your specific application area.

For more information and access to Aurora® Online:

www.tatasteleurope.com/aurora

E: connect.automotive@tatasteleurope.com

www.tatasteeleurope.com

While care has been taken to ensure that the information contained in this publication is accurate, neither Tata Steel, nor its subsidiaries, accept responsibility or liability for errors or for information which is found to be misleading.

Before using products or services supplied or manufactured by Tata Steel and its subsidiaries, customers should satisfy themselves as to their suitability.

Copyright 2019
Tata Steel Europe Limited

Tata Steel

Automotive

PO Box 10.000

1970 CA IJmuiden

The Netherlands

E: connect.automotive@tatasteeleurope.com

www.tatasteeleurope.com/automotive

AM:EN:PDF:1119