

Road Regulations

Regulations for External Road Transport of Steel Products



Blank page

Introduction

- These regulations are made up from several parts. These parts contain the relevant information for a haulier that undertakes road transport of product under the responsibility of or ordered by Tata Steel .
- The following table of contents shows the Road Regulation documents that are currently applied on the IJmuiden site of Tata Steel Europe and should be known to the haulier before they enter the site.
- Tata Steel Europe is currently undertaking a project to unify its Load Securing methods and systems across the company. This has resulted in the inclusion of two types of load restraint documents into these Road Regulation.
- A conscious decision has been made to identify these two different documents so that the haulier can identify which method has been adopted by all Tata Steel Europe sites and which method is to be applied for transport under the responsibility of or ordered by Tata Steel in IJmuiden.

Table of Contents

Part 1 Site access/procedures

1.1	Access control	1-1
1.2	Personal protection equipment	1-2
1.3	Personal behaviour	1-3

Part 2 Equipment requirements

2.1	General requirement	2-1
2.2	Vehicle requirements	
2.2.1	DME	2-1
2.2.2	Headboard	2-1
2.2.3	Trailer Floor	2-1
2.2.4	Well (Trailers and Coiltainers)	2-2
2.2.5	Stanchions (coil securing posts)	2-2
2.2.6	Securing points	2-2
2.2.7	Weather superstructure	2-3
2.2.8	Roof Pole	2-3
2.3	Securing equipment requirements	
2.3.1	Webbing straps and ratchets	2-4
2.3.2	Transport chains and tensioners	2-4
2.3.3	Webbing strap edge protection	2-5
2.3.4	Anti-slip matting	2-5
2.3.5	Coil Cradles	2-6
2.3.6	Stillages	2-6
2.4	Technical information sheets (TIS)	
2.4.1	Description	2-7

Part 3 Co-loads (additional cargo)

3.1	Types of additional cargo	3-1
3.2	Loading and unloading	3-3
3.3	Securing	3-3
3.4	Exceptions	3-3

Part 4 Securing methods

4.1	Description	4-1
4.2	Explanation	
4.2.1	IJmuiden Road Regulation Guideline	4-1
4.2.2	Tata Steel Load Restraint Guideline	4-1
4.3	Securing methods/guidelines	4-2
4.4	Return Cargo	
4.4.1	Packaging	4-3
4.4.2	Securing	4-3

Part 5 Organisation and management

5.1	Application	
5.1.1	Responsibility	5-1
5.1.2	Application	5-1
5.1.3	Standards	5-1
5.1.4	Inspection	5-1
5.1.5	Penalty Policy	5-2
5.2	Document Control	
5.2.1	Publication method	5-3
5.2.2	Validity	5-3
5.2.3	Archive	5-3
5.2.4	Authorisation	5-3
5.2.5	Change list	5-4

Part 6 Appendices

6.1	Technical advice documents / Specific equipment documents	6-1
-----	--	-----

Blank page

1. Site access/procedures

1.1 Access control

- A driver must have the following documents and information to gain entrance to the loading locations of Tata Steel:
 - Identification document
 - Company name
 - Registration of towing vehicle
 - Number of transport
 - Total weight of the load to be loaded

- Access will be refused when the driver:
 - Has any blood alcohol level
 - Is accompanied by pets or unauthorised passengers.
 - Demonstrates inappropriate behaviour

- Drivers are obliged to show their personal protection equipment when asked to do so at the time of request for access or at any time whilst on site.

1.2 Personal protection equipment

Drivers must have and use the following personal protection equipment:

- Hard hat to EN 397: 1995
Yellow and orange coloured hats are not allowed.
- Safety shoes with reinforced toecaps to EN 20345: 2004 type S3.
- Clothing to cover the entire body. Shorts or short sleeves are not allowed.
- Reflective clothing/vest.



The following additional personal protection equipment is required depending on the location for loading:

- Safety goggles to EN 166: 2001
- Hearing protection



The use of the following personal protective equipment is recommended:

- Cut-protection safety gloves



1.3 Personal behaviour

Drivers are required to work in a safe way and behave according to general standards at both loading and unloading locations.

Drivers must:

- Adhere to the Tata Steel General Safety Standards.
- Wear the prescribed personal protection equipment.
- Strictly follow the safety regulations at the locations for loading.
- Wear a valid admission pass where it can be clearly seen.
- Always apply the handbrake whenever the vehicle is parked.
- Report to the dispatch office on arrival.
- Stay with the vehicle.
- Always use the roof pole to open or close the roof of the trailer in a safe way.
- Only drive their vehicle into the loading bay after receiving permission from the dispatch staff.
- Strictly follow the instructions of the dispatch staff.
- Stay within the green area of the exclusion zones during loading.
- At least secure the load as described in the Tata Steel Road Regulations.
- Fill in and sign the CMR document (waybill) after the loading is completed and before departure.
- Make remarks on the CMR when the load is not delivered properly.
- Notify the dispatch staff when departing.

Drivers must not:

- Open or close the roof in an unsafe way. Never climb on the weather hood.
- Be in the red or yellow areas of the exclusion zone during loading.
- Touch the load or the hoist, or guide these by hand.
- Operate installations belonging to Tata Steel, for example cranes and fork-lift trucks.
- Enter any other part of the loading bay than where the loading takes place.
- Urinate elsewhere than on a therefore equipped place (toilet).

Blank page

2. Equipment requirements

2.1 General requirement

- The vehicle and equipment must be maintained in such a way that it is safe to work on and with.

2.2 Vehicle requirements

2.2.1 DME

- Vehicles loading in IJmuiden must meet the Euro 4 of Euro 5 norm. Euro 3 vehicles will only be accepted with a particle filter filtering for at least 70%. Euro 1 en 2 vehicles are not permitted.

2.2.2 Headboard

- If used to restrain the load the headboard strength must be atoneable by form of a certificate or plaque . The head board must be well maintained and undamaged.

2.2.3 Trailer Floor

- The loading platform should be flat, solid and well-maintained. When a coil well is present it must be possible to fully cover the well to present a solid loading platform.
- There should be no missing or broken boards for covering a coil well. Refer to Technical Information sheet TIS-0003 for further requirements for well boards.
- There should be no risk of the load becoming wet from underneath.
- The trailer bed must be clean and dry when the vehicle arrives for loading. Clean means: free of odour, dirt and fluids. If the Tata Steel dispatcher decides the trailer is not clean it will not be loaded.

2.2.4 Well (Trailers and Coiltainers)

- The sides of the well should have a minimum angle of 30 degrees to the horizontal.
- A coil placed in the well must be clear of the bottom by at least 20 mm.
- The points of support of the coil must be distinctly lower than the upper rim of the well.
- When it is unclear if the coil lies correctly in the well, a sheet of paper will be used to check that the point of support is lower than the upper rim of the well.

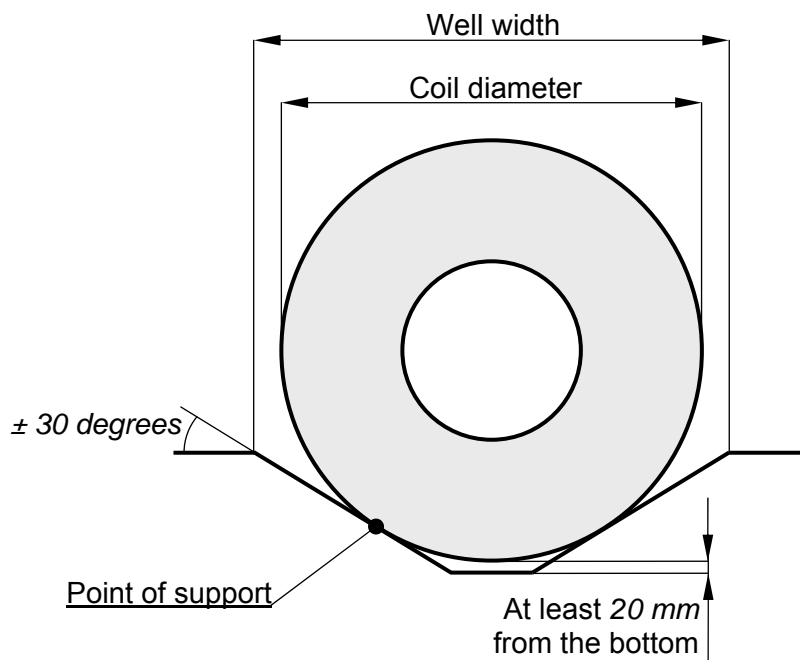

2.2.5 Stanchions (coil securing posts)

- The use of stanchions is recommended, especially for coils in a well. The use of stanchions is mandatory for transport of coils sensitive for tipping and/or are of 10 tonnes or more in weight. Refer to LRG 0008 for further information on topple sensitive coils and coil weights.
- The use of stanchions is allowed combined with all securing methods for horizontal and vertical (ETTS) coils and Tinplate sheet packs.
- A driver must be able to prove the safe working load of the stanchions to make it possible to calculate whether the load securing is sufficient.
- Stanchions must at least be as high as half the height of the coil when placed in the well.

2.2.6 Securing points

- The securing points should be integrated in the vehicle construction.
- Each securing point should be capable of withstanding the prescribed forces as described in the Load Restrain Guideline for the load to be transported.

- There should be enough securing points for securing according to the prescribed securing methods.
- Refer to Technical Information Sheet TIS-0009 for further requirements for securing points.

2.2.7 Weather superstructure

- Products must be covered in such a way that they remain dry.
- The weather hood must be retractable so that it does not interfere with the loading process.
- When the weather hood is not retractable it should be possible to remove the weather hood rapidly and in a way that the driver can always work safely on the trailer bed.
- Trailers which have a framework and cover to be disassembled before loading and have to be setup after loading, are not permitted.
- The weather superstructure must be at least 10 cm above the load.
- The weather hood should not have any tears or other deficiencies that could result in leakage.
- When loading ETTS coils, tinplate packages or horizontal coils on a Tata Steel cradle the trailer must be accessible from the back and the side.

2.2.8 Roof Pole

- The roof should always be opened with suitable equipment (roof pole).
- The roof pole must be in good condition and well-maintained.
- Before using a telescopic roof pole one must determine the locking pin functions correctly and that the pole can be used safely.

2.3 Securing equipment requirements

2.3.1 Webbing straps and ratchets

Requirements

- Straps should demonstrable comply with the EN12195-2 standard, by means of a label on the web lashing and a classification on the ratchet.
- The strap must have a hand-operated ratchet tensioner.
- The length of the straps has to be sufficient for the securing method. Straps with a minimum length of 8.5 m are required for securing ETTS coils.
- Straps should be visually inspected before every journey.
- The end fitting of the strap must be suitable for the type of securing point used.
- Refer to Technical Information Sheet TIS-0003 for further requirements for web straps and ratchets.

No-go standard

- In accordance with EN12195-2, TIS-0003 and information from the manufacturer.

2.3.2 Transport chains and tensioners

Requirements

- Lashing chains must demonstrable comply with the EN12195-3 standard, by means of a metal tag attached to the chain.
- Lashing chains should be visually inspected before every journey.
- The use of spring links (overcentre loadbinders) is not permitted.
- The end fitting of the chain must be suitable for the type of securing point used.
- Refer to Technical Information Sheet TIS-0004 for further requirements for transport chains and tensioners.

No-go standard

- In accordance with EN12195-3, TIS-0004 and information from the manufacturer.

2.3.3 Webbing strap edge protection

Requirements

- Edge protectors must consist of products available as such on the market. The use of friction enhancing material (anti slip matting) is not permitted.
- The use of edge protection is mandatory for loads where the edge radius is less than the thickness of the web lashing used.
- The shape and size of edge protectors must fit the used loading restraint material.
- Refer to Technical Information Sheet TIS-0005 for further requirements for webbing strap edge protection.

No-go standard

- An edge protector needs replacement when damage to the protector hinders the correct working of the protector therefore leading to the possibility of damage to either the webbing strap or the load.

2.3.4 Anti-slip matting

Requirements

- The anti-slip mats should have friction coefficient (μ) of 0.6 or more.
- The anti-slip mats should have a thickness of at least 8 mm.
- Refer to Technical Information Sheet TIS-0008 for further requirements for anti-slip matting.

Use

- Anti-slip mats must be placed in a way the load doesn't touch the trailer bed directly and the trailer bed will not be touched after a small movement of the load.
- Anti-slip mats must remain partly visible when placed under a load

No-go standard

- When the anti-slip mat is breaking apart the material should be replaced.
- When the friction coefficient of the anti-slip mats is questionable, the driver or carrier will have to prove that the mats have the required friction coefficient.
- Old conveyer belt, bike tyre and so on are not made of anti slip material.

2.3.5 Coil Cradles

When a horizontal coil has to be transported on a trailer without a well the coil can be supported by a cradle. The requirements of the cradle are as follows:

- The cradle should provide a stable support for the coil.
- The beams that support the coil must cover the full width of the coil.
- There must be provisions for fixing the distance between the beams in both directions.
- The points of support of the coil must be distinctly lower than the upper edge of the cradle.
- A coil placed in a cradle must be clear of the loading platform or cradle construction for at least 20 mm.
- The use of anti-slip mats between the loading platform and the coil cradle is mandatory when the cradle is not fixed to the trailer.

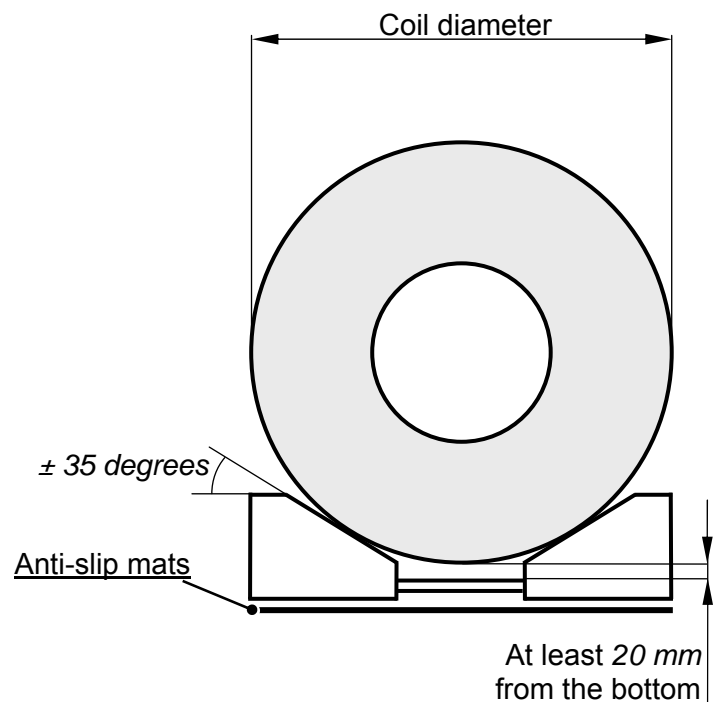

2.3.6 Stillages

- Stillages must fit the coil to be transported.
 - A stillage should not be too large so it cannot sufficiently support the coil.
 - The stillage should not be too small so the coil lies on the edge of the stillage.
- Stillages must be in a good condition.
- Stillages are to be used only in combination with blocking in forward direction.

2.4 Technical information sheets (TIS)

2.4.1 Description

These technical information sheets represent the Tata Steel Europe requirements for haulier equipment. Hauliers are required to conform to these requirements when the equipment is used to restrain Tata Steel Europe products. Failure to meet these requirements can lead to the load being refused.

- The TIS documents in force within these Road Regulations are listed below:

Webbing straps and ratchets (TIS 0003 Issue 1)

Transport chains and tensioners (TIS 0004 Issue 1)

Webbing strap edge protection (TIS 0005 Issue 1)

Well boards for well trailers (TIS 0006 Issue 1)

Anti slip matting (TIS 0008 Issue 1)

Blank page

TECHNICAL INFORMATION SHEET

Webbing straps and ratchets

Webbing straps in combination with ratchet tensioners must be used on a number of Tata Steel products to ensure the customer receives only the highest quality product.

1. Terminology

Lashing capacity

Maximum allowable tension in the lashing.

- **Lashing capacity is NOT to be mistaken for the allowable weight of product the lashing can safely restrain.**
- When designing a restraint system and determining the required number of restraints, it is the lashing capacity and not the breaking force which must be taken into account.
- A 2-tonne lashing capacity webbing strap will be denoted by LC 2000daN.

Breaking force

Maximum force the web lashing withstands when tested complete with ratchet and end fittings.

- The breaking force of the lashing assembly will be twice the lashing capacity.

2. Identification

Lashing capacity	LC daN
Standard hand force*	S_{HF} 50 daN
Standard tension force	S_{TF} daN
Webbing material	POLYESTER
Length	... m
	"NOT FOR LIFTING!"
Name of manufacturer or supplier	
Manufacturer's traceability code	CODE NR #####
Year of manufacture	DD MM YYYY
Standard	BS EN 12195-2

Blue label

- Preferred option.
- Polyester (PES) webbing.
- Resistant to mineral acids.
- Attacked by alkalis.

Green label

- Polyamide (PA) webbing.
- Virtually immune to effects of alkalis.
- Attacked by mineral acids.

Brown label

- Not to be used on steel products.
- Polypropylene (PP) webbing.
- Little affected by mineral acids and alkalis.
- Low lashing capacities.



Tata Steel recognises the fact that the identification label of a webbing strap or tensioner may become damaged without any consequence to the integrity of the restraining equipment. The minimum information which must remain legible are the lashing capacity and the standard to which the item has been manufactured, i.e. EN 12195-2.

* An applied force of 50kg (daN) to the handle, will typically result in 350kg (daN) of tension in the lashing.

3. Web lashing types

- Webbing straps and ratchets with the following lashing capacities are suitable for use on Tata Steel products:
 - LC 2000daN, LC 2500daN and LC 4000daN (typically 50mm wide)
 - LC 5000daN (typically 75mm wide)

Ratchets are available as *Pull up to tension* or *Pull down to tension*, to ensure the most ergonomic action for the orientation of the ratchet.

- Short handle ratchets can achieve a Pre-Tension in the region of 200-450 daN.
- Long handle ratchets can achieve a Pre-Tension in the region of 300-600 daN.

TECHNICAL INFORMATION SHEET

Webbing straps and ratchets

4. Inspections

- Check the identification label of the equipment to ensure they are manufactured to EN 12195-2 and that the lashing capacity corresponds with the adopted securing method.
- Inspect the equipment for wear and tear as detailed below.

The following criteria are considered to be signs of damage:

- For web lashings: tears, cuts, nicks and breaks in load bearing fibres and retaining stitches; as well as deformations resulting from exposure to heat.
- For end fittings and tensioning devices: deformations, splits, pronounced signs of wear, signs of corrosion.
- Accidental contact with chemical products.



Cuts/chafing across width.
Result of inadequate edge protection.

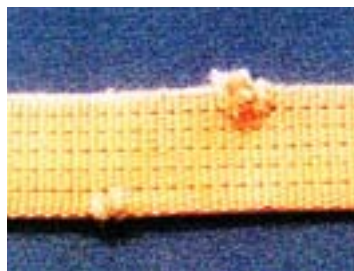

Frayed edge.
No more than 10% damage across the width is permissible.

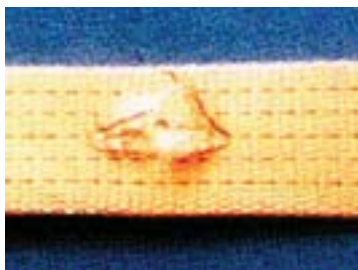

Damaged core.



Never use with knots.
Knots can reduce the capacity by a half.

5. Failure modes

- Clean cut through strap is an indication of slicing failure. Likely cause is inadequate edge protection.
 - Suitable edge protection required on all unprotected, sharp edges with radius less than 3mm.
 - Edge protection recommended on all abrasive products in order to extend lifetime of webbing strap.
 - See Technical Information Sheet on Edge Protection for more detailed information. Ref No. TIS-0005.
- Frizzy ends are an indication of tension failure. Likely cause is an inadequate number of restraints.

6. Anchoring

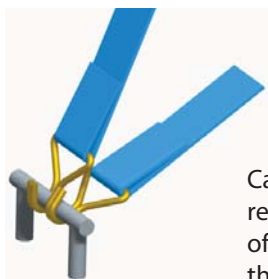

Capacity of webbing strap is reduced by 50% when both ends of the same strap are attached to the same anchor point.

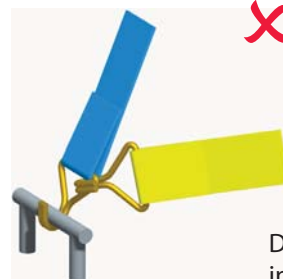

Do not anchor a webbing strap into the hook of another.

Warning!

Do NOT substitute a chain with a webbing strap. Do NOT substitute a webbing strap with a chain.

Lashing capacities and stretch characteristics of webbing straps and chains differ significantly. When loaded to lashing capacity a webbing may stretch by up to 7%, whereas a chain will only stretch 2%.

Care has been taken to ensure that the contents of this publication are accurate, but Tata Steel Europe Limited and its subsidiaries do not accept responsibility or liability for errors or information that is found to be misleading.

TECHNICAL INFORMATION SHEET

Transport chains and tensioners

1. Terminology

Lashing capacity

The maximum allowable tension in the chain.

- **Lashing capacity is NOT to be mistaken for the allowable weight of product the lashing can safely restrain.**
- When designing a restraint system and determining the required number of restraints, it is the lashing capacity and not the breaking force which must be taken into account.
- A 4-tonne lashing capacity chain will be denoted by LC 40kN.



Breaking force

Maximum force the complete chain lashing, including load binder and connection components, can withstand.

- The breaking force of the lashing assembly will be twice the lashing capacity.

2. Chain condition

The following are considered to be signs of damage:

- Excessive wear: chain exceeds allowable wear.
 - 8mm chain reduced to 7.2mm.
 - 10mm chain reduced to 9mm.
- Twisted, bent or elongated links.
- Gouges or nicks: corners of product leading to damage on chain.
- Key hole effect.
- Cracks in the weld area.
- Severe corrosion.

Never heat, weld or heat treat a chain.

Never secure a chain with a knot or bolt two chains together to increase length.



X Gouged.



X Key hole effect.



X Bent.



X Twisted.

3. Chain Checker Card

A useful tool, the size of a credit card, for determining lashing angles and wear of chain links.

Images of card are not to scale.

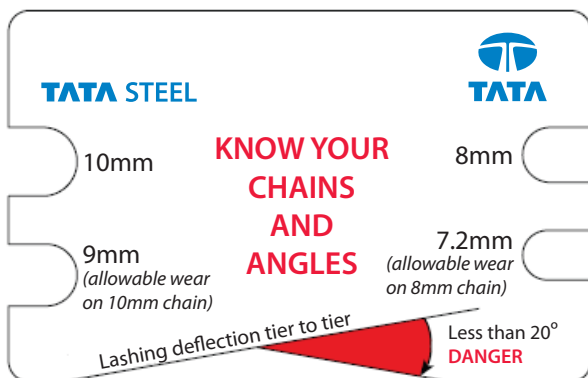

Front.

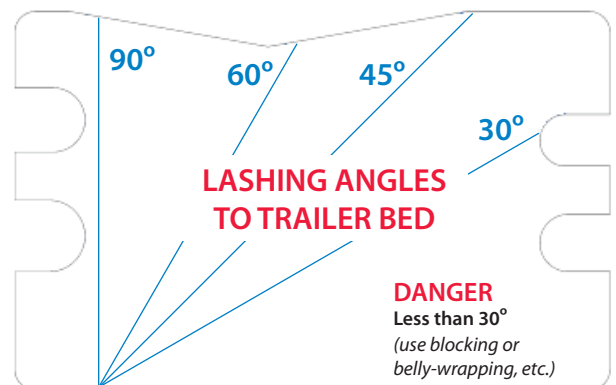

Back.

TECHNICAL INFORMATION SHEET

Transport chains and tensioners

4. Chain grades and sizes

7mm Grade 8 chain

- 3-tonne lashing capacity.
- 1.1 kg per metre length of chain.

8mm Grade 8 chain

- 4-tonne lashing capacity.
- 1.4 kg per metre length of chain.

10mm Grade 8 chain

- 6.3-tonne lashing capacity.
- 2.2 kg per metre length of chain.

All chains must be Grade 8 or 80. These are 'high-tensile' chains.

Many incorrectly believe their 6mm or 7mm chains are acceptable because they are 'high-tensile'.

The most important factor to establish is the lashing capacity.

The capacities of chains are downrated by 25% to allow for bending of links over the product, against trailer and/or in the tensioner grap hooks.

5. Tensioner types

Bottle tensioner

- Can achieve a standard tension force of up to 3150daN, but typically this figure will be closer to 1000daN.
- Can be procured to match the Lashing Capacity of the chain.

Webbing ratchet

- Long handle webbing ratchets can achieve a Pre-Tension in the region of 200-600 daN.
- Lashing capacity of webbing ratchet will differ from that of the chain. Lowest capacity item determines the capacity of the complete lashing system.
- Webbing ratchets are available in 2-tonne, 2.5-tonne and 5-tonne specifications.

Overcentre loadbinder

- Overcentre loadbinders, also known as Sylvesters, are banned on all Tata Steel sites.



6. Storage

Never leave unsecured chains or tensioners on the deck of the trailer.



Securing equipment contained in a tray.



Loose chains on trailer deck can slide off.

Warning!

Do NOT substitute a chain with a webbing strap. Do NOT substitute a webbing strap with a chain.

Lashing capacities and stretch characteristics of webbing straps and chains differ significantly.

When loaded to lashing capacity a webbing may stretch by up to 7%, whereas a chain will only stretch 2%.

Care has been taken to ensure that the contents of this publication are accurate, but Tata Steel Europe Limited and its subsidiaries do not accept responsibility or liability for errors or information that is found to be misleading.

TECHNICAL INFORMATION SHEET

Webbing strap edge protection

This Technical Information Sheet outlines the importance of edge protection for webbing straps that are used to restrain steel loads for road transport.

1. Purpose

Edge protection is required to protect the strap from sharp or abrasive edges of the product or trailer. Failure to apply appropriate edge protection to the strap introduces the risk of cutting the strap and losing some or all of the restraint on the product.

Edge protection also reduces the stress on the outer fibres of the strap by increasing the radius of the corner. Using the a strap over a tight corner without edge protection will reduce strap strength significantly.



It is important to note that each strap used to keep the product on the trailer works as part of a system of restraints where failure of one component could compromise the entire system.

2. Where to apply

- ✓ Straps must be protected when in contact with any corner of the product or trailer with a radius of less than 3mm.
- ✓ Every point where the strap is in contact with a sharp or abrasive edge of the product **MUST** be adequately protected.
- ✓ Where straps are anchored to the trailer chassis beam, edge protection **MUST** be applied to protect the strap from trailer side raves.

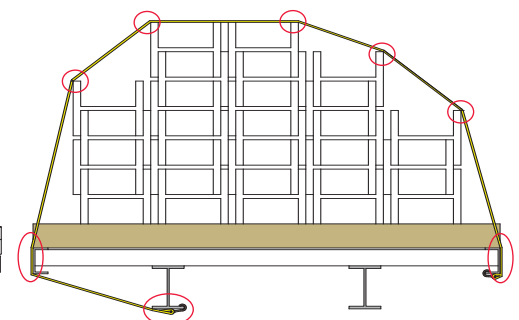
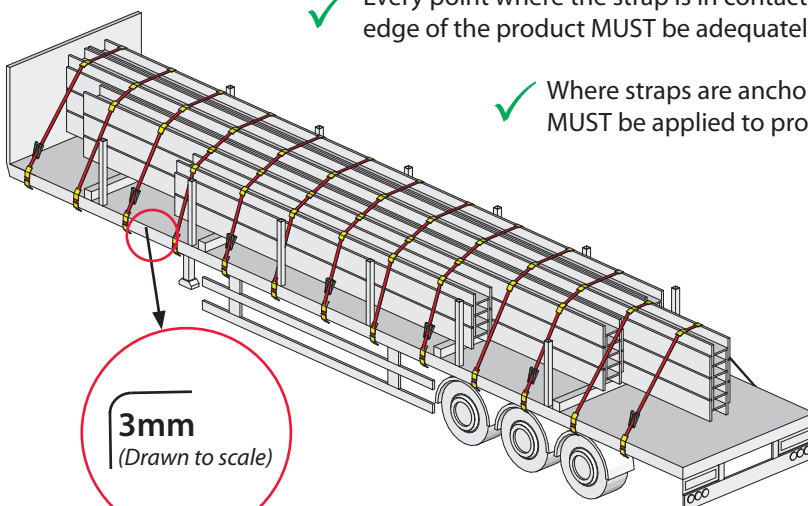

TECHNICAL INFORMATION SHEET

Webbing strap edge protection

3. Requirements

- Edge protection **MUST** be appropriate for the method of restraint being used:
 - high level of abrasion and cut resistance against sharp and/or rough edges of the product or trailer;
 - flexible enough to form to the shape of curved edges without damage e.g. coil bore;
 - ensure straps cannot slide off during use.

4. Examples of good and poor edge protection

✓ Heavy duty webbing wear sleeve (Polyester, minimum 3mm thick)



- ✓ Excellent abrasion resistance.
- ✓ Good flexibility.
- ✓ Recommended edge protection for ALL steel loads.

✗ Lightweight wear sleeve



- ✗ Poor abrasion resistance.
- ✗ Poor cut resistance.
- ✗ NOT to be used as edge protection for steel products.

✓ Coil bore packaging



- ✓ Good abrasion resistance.
- ✓ Good flexibility.
- ✗ Slippery - NOT to be used with tie-down restraints .
- ✓ Recommended for direct restraints through coil bores.

✗ Foam edge protection



- ✗ Poor abrasion resistance.
- ✗ Poor cut resistance.
- ✗ NOT to be used as edge protection for steel products.

✓ Plastic corner protectors



- ✓ Good abrasion resistance.
- ✗ Poor flexibility.
- ✓ Ideal for tie-down restraints.
- ✓ Recommended edge protection for straight edges ONLY.

✗ Cardboard corner protectors



- ✗ Poor flexibility.
- ✗ Slippery - NOT to be used with tie-down restraints .
- ✗ NOT recommended as edge protection for steel products.

It is NOT acceptable to use anti-slip matting as a substitute for edge protection.

Care has been taken to ensure that the contents of this publication are accurate, but Tata Steel Europe Limited and its subsidiaries do not accept responsibility or liability for errors or information that is found to be misleading.

TECHNICAL INFORMATION SHEET

Well boards for well trailers

This Technical Information Sheet outlines the requirements for well boards that are used for blocking when transporting steel coils in the well.

1. Well board design

- Well boards must be matched to the trailer well in which they are used:
 - same **well angle** to provide support to the well board when used as part of the trailer deck
 - same **well width** to ensure correct coverage and edge support
 - same **well lip depth** to ensure well-board does not cause a tripping hazard.
- Well boards should be designed to provide the same **vertical loading** capability as the trailer bed (able to withstand forklift axle load of 5.46 tonnes).
- Well boards should be capable of withstanding **horizontal loading** of 10 tonnes in compression.
- Well boards can be manufactured in various ways to provide sufficient strength, for example:

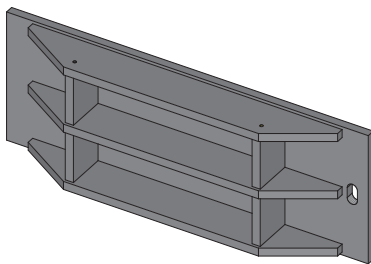
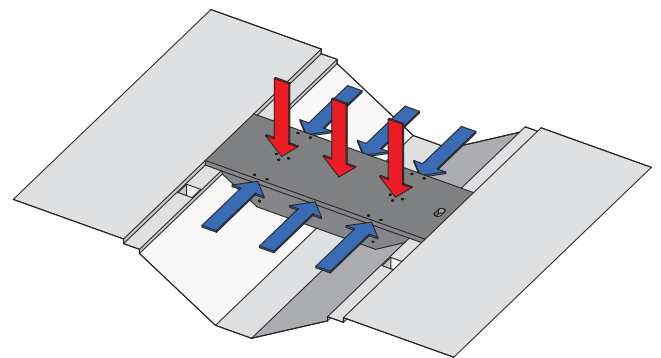

- ✓ Plywood frame.
Minimum thickness 25mm first grade ply.

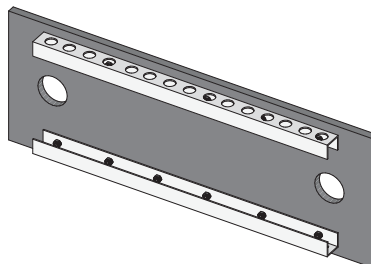

- ✓ Longitudinal steel members - no cross bracing. Minimum thickness 25mm first grade ply.

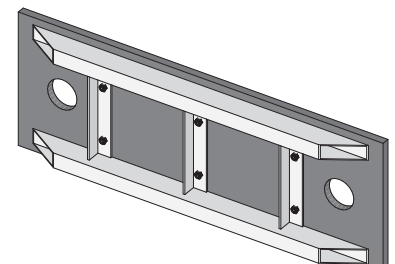

- ✓ Steel frame with cross bracing. Minimum thickness 20mm first grade ply.

2. Well board condition

Key areas to inspect include:

- Frame condition and joints
 - check for cracks / splits / gaps.
- Fixing of decking surface to frame
 - check for missing or loose screws / bolts.
- Condition of decking surface
 - check for warping and de-lamination.
- Edges must not be chamfered or worn.
- Well boards must fit square and flat in the well.

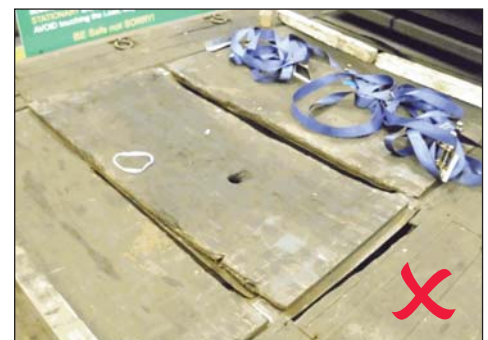

TECHNICAL INFORMATION SHEET

Well boards for well trailers

3. Use of well boards for blocking

3.1 Against well posts

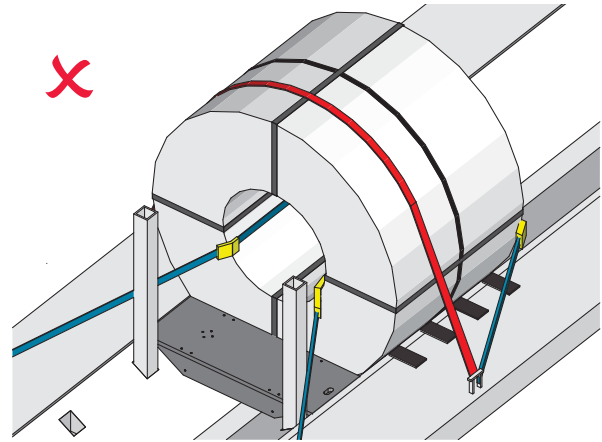
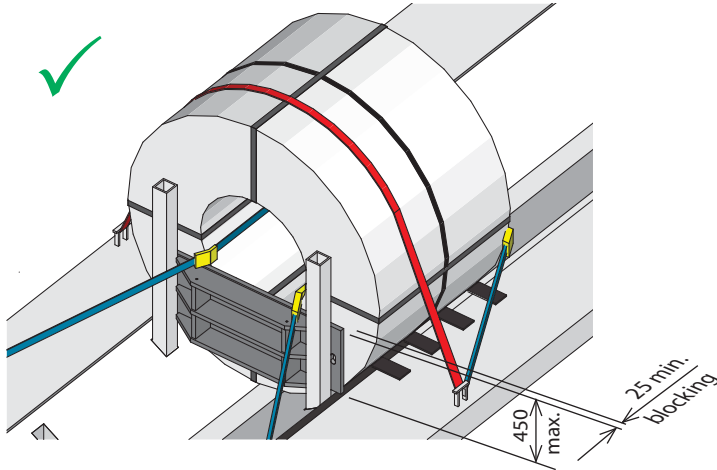

- ✓ Well board fits flush between posts and coil.
- ✓ Well board cannot slide out sideways.
- ✓ Maximum well board height 450mm to keep bending force low down on the posts.
- ✓ Minimum blocking thickness 25mm when used in this orientation to ensure coil does not topple against upper part of posts.

- ✗ Do not use a well board horizontally as spacing between the coil and **well posts**. The well board edges will crush due to concentrated point loading under heavy braking.
- If spacing is needed between well posts and coil to achieve axle loadings, then use minimum 100mm square timbers as blocking.

3.2 Multiple coils

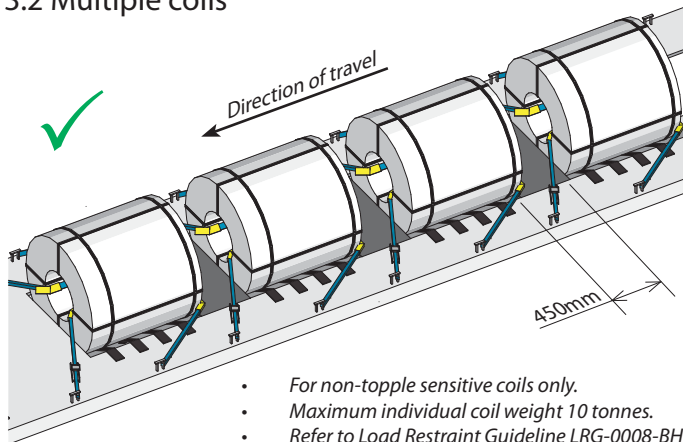

- For non-topple sensitive coils only.
- Maximum individual coil weight 10 tonnes.
- Refer to Load Restraint Guideline LRG-0008-BH for Wide coil in well.

- ✓ 450mm wide well boards will provide sufficient access for crane tongs in the majority of cases.
- If additional spacing is required between coils wider **higher strength** boards should be used:
 - minimum of 25mm thick first grade ply.
 - secured to frame with cross members.
 - recommended maximum width of a single well board is 600mm.
- ✓ Front coil must be placed against front of well or against well posts to provide load restraint in forward direction - **relying on a well board against the front lip of the well is not sufficient.**
- ✓ Maximum of **one** well board between coils to avoid flipping out under load.

- When used as blocking between coils, the well boards must have clean square edges to ensure that they do not flip out under load.
- Well boards must have a minimum decking thickness of 20mm to ensure adequate spread of load across the coil faces.

Well boards are an integral part of the restraint systems shown above and must be inspected regularly.

Care has been taken to ensure that the contents of this publication are accurate, but Tata Steel Europe Limited and its subsidiaries do not accept responsibility or liability for errors or information that is found to be misleading.

TECHNICAL INFORMATION SHEET

Anti-slip matting

This Technical Information Sheet highlights the contribution of anti-slip matting to load restraint systems used to restrain steel loads for road transport.

1. Specification for anti-slip matting



Coefficient of friction: 0.6 (minimum).

Recommended thickness: 10mm is suitable for most applications. Thinner matting may not fully isolate the load from the cargo bed. Matting below 8mm will tear too easily when used with steel loads. Matting above 15mm thick may shear when used with steel loads.

Material: Typically 1-3mm rubber granulate made from recycled materials and bound with polyurethane elastomer.

Colour: Typically black with multicoloured speckling, but may be supplied in a variety of colours.

Surface texture: Fine granular texturing.

Porous / Non-porous: High level of porosity is desirable.

Working temperature range: -20 °C to +100 °C.

Tensile strength: 0.6 N/mm² minimum.

Anti-slip matting is available as either loose pieces or strips, typically 1m long x 100mm wide.

2. How anti-slip matting works

Friction is the resistance of an object to sliding. It is a critical factor in most load restraint systems with its value depending solely on the product weight and surface roughness, and not surface area.

The application of anti-slip matting for the purpose of load restraint increases the friction between adjacent surfaces, for example between the surface of the steel product and the trailer deck.

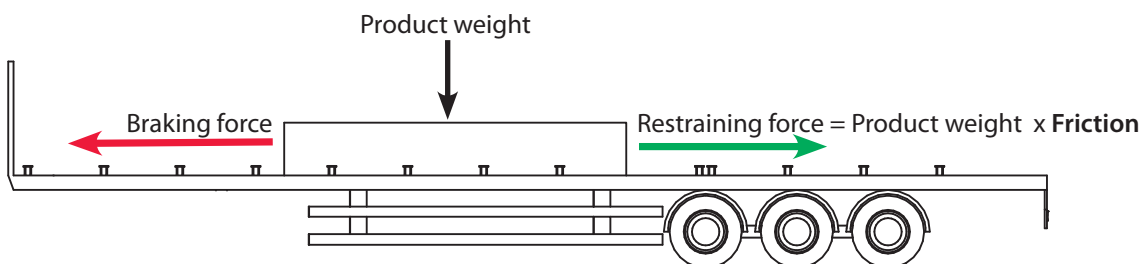

High friction creates more efficient and effective load restraint systems.

Some typical friction coefficients are listed below:

Oiled Steel on Steel = 0.2 (**Low**).

Steel on Wood = 0.4 (**Medium**).

Steel on Anti-Slip Matting = 0.6 (**High**).

TECHNICAL INFORMATION SHEET

Anti-slip matting

3. Using anti-slip matting

Anti-slip matting may be applied as a whole mat or as loose strips provided that the strips are adequately spaced to effectively prevent steel on steel or steel on wood contact.

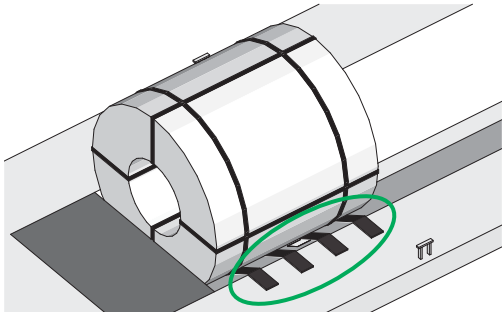

✓ Strips of matting adequately spaced to ensure no contact between the product and the trailer.

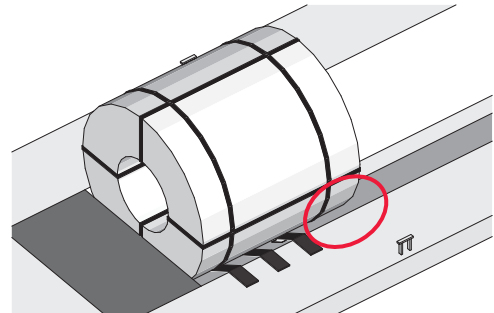

✗ Inadequate and/or poorly positioned anti-slip matting allows product to rest on the trailer bed.

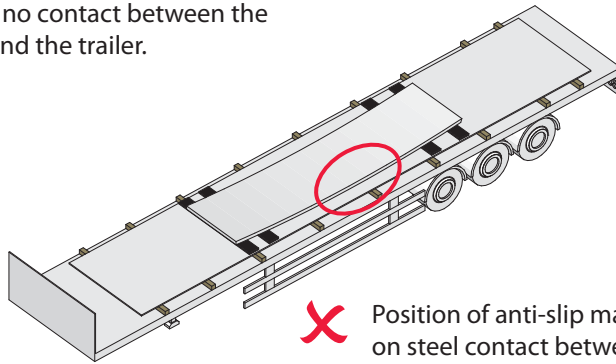

✗ Position of anti-slip matting allows for steel on steel contact between product layers.

Note: It is important to ensure that the anti-slip matting is visible beneath the product for inspection purposes.

4. Anti-slip matting on timber bearers

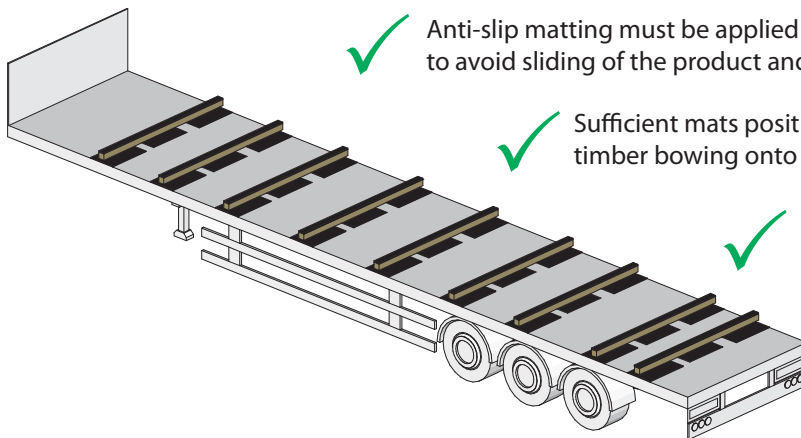

✓ Anti-slip matting must be applied on top and beneath each timber bearer to avoid sliding of the product and timbers across the trailer deck.

✓ Sufficient mats positioned beneath the timber to prevent the timber bowing onto the trailer deck.

✓ Anti-slip matting may be nailed on to the timber bearers or bonded using suitable adhesives.

Note: While the anti-slip matting is applied, it is necessary to avoid dragging the product across the surface of the anti-slip matting as this will cause the mats to become dislodged or torn, rendering them ineffective.

Warning!

It is NOT acceptable to use anti-slip matting as a substitute for edge protection.

Conveyor belting and other forms of rubber are NOT acceptable alternatives where Load Restraint Guidelines specify anti-slip matting as they have a significantly lower coefficient of friction.

Care has been taken to ensure that the contents of this publication are accurate, but Tata Steel Europe Limited and its subsidiaries do not accept responsibility or liability for errors or information that is found to be misleading.









3. Co-loads (additional cargo)

3.1 Types of additional cargo

- All non-Tata Steel material is considered additional cargo, this includes haulier equipment within the trailer.
- Tata Steel has the right to demand a list of all goods that are to be loaded during a certain period.
- A minimum distance of 500 mm should be left between the Tata Steel load and the co-load.
- Additional cargo is only permitted on the first four meters of the trailer when transporting or loading Tata Steel Packaging (TSP) ETTS coils.
- In case of a combination truck additional cargo is only permitted on the first two meters.
- Many customers require the trailer to be accessed via the rear doors. Provision should be made for this.

Not permitted are:

- Chemicals (toxic, noxious, irritating or corrosive products) or explosive goods.
- Co-loads that exhibit the following GHS symbols are not allowed:

- | | | | |
|-------------|---|--|--|
| ▪ Explosive |  |  | ▪ Acutely toxic |
| ▪ Flammable |  |  | ▪ Irritating
Sensitizing
Harmful |
| ▪ Oxidant |  |  | ▪ Long term
health
hazard |
| ▪ Corrosive |  |  | ▪ Hazardous
to aquatic
environment |

- Perishable goods.
- Additional cargo damaging the packaging and Tata Steel products.
- Bulk materials, either loose, palletised or in big bags.
- Additional cargo not fitting within the dimensions of the trailer.
- Additional cargo or residue thereof affecting the Tata Steel products by its odour or by contamination. Therefore empty packaging from chemicals is also not permitted.

3.2 Loading and unloading

- Additional cargo must not delay loading at Tata Steel.
- Additional cargo must not delay unloading at the customer's premises.
- Additional cargo must not affect the delivery time that has been agreed with the customer.
- Preferably, the Tata Steel products should be loaded first and then the additional cargo.
- If additional cargo is loaded first and then problems arise with the loading of Tata Steel material, any resultant costs may not be claimed from Tata Steel.

3.3 Securing

- All additional cargo and haulier equipment (well boards for example) must be adequately secured with approved securing materials to prevent shifting.
- The web lashing on the Tata Steel products are not to be loosened or removed to place additional cargo on the trailer.

3.4 Exceptions

- For some customers no additional cargo is permitted at all.
- When three or more ETTS coils have to be transported, no additional cargo is allowed.

Blank page

4. Securing methods

4.1 Description

This Road Regulation includes two type of restraining documents.

- The first is the Road Regulations Guideline. This is an extension of the IJmuiden Securing method. These guidelines are formatted in the Road Regulation style.
- The second is the Load Restraint Guideline. This is a Tata Steel Europe wide guideline and can be identified by the application of a LRG number and a different format to the rest of this document.

4.2 Explanation

4.2.1 IJmuiden Road Regulation Guideline

- The left part of a page describes the needs for every method and gives a step by step explanation of loading and securing.
- The right part of the page gives a visual step by step explanation of loading and securing.
- When applicable, green lines give the location of the angle mentioned in the text.
- The arrow in the drawing indicates the driving direction.

4.2.2 Tata Steel Load Restraint Guideline

- The first sections lay out the requirements for the load restraint system.
- If applicable the different methods are then described with an explanation as to how they should be applied.
- Finally, further information is given if this is important to the restraint system.

4.3 Securing methods/guidelines

Wide coil in the well (LRG 0008-BH Issue1)

Horizontal coils on cradles

Horizontal coils on stillages

Coil ends on a flat floor

Damaged coil in the well

Vertical (ETTS) coils

Vertical slit coils

Tinplate sheet pack

LOAD RESTRAINT GUIDELINE

Wide coil in well

750mm minimum sheet width

2000mm maximum diameter

1. This guideline applies to:

- All wide coils, loaded bore horizontal in a well trailer.
- Coils are classed as **stable** or **topple sensitive** based on the ratio of outside diameter (OD) to sheet width (SW).

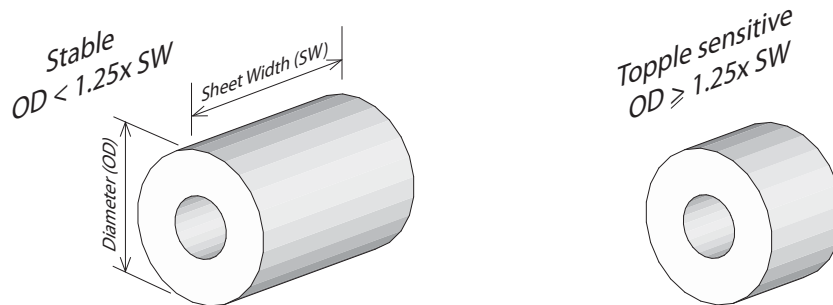

- The following coils are classed as **low friction**:
 - Coils that have been wrapped in plastic film or paper.
 - Coils that have been pickled and oiled, galvanised, painted or coated.
 - Cold rolled coils.

2. Essential requirements

- All webbing straps must have a minimum lashing capacity of 2000 daN (unless otherwise stated) and must be compliant with EN 12195-2.
- All lashing points must be rated to a minimum working load limit corresponding to the lashing capacity of straps used.
- Edge protection must be used on all unprotected, sharp corners.
- Well posts must be minimum section size of 80 x 80mm with 5mm wall thickness and steel grade S355 in accordance with EN 10210.
- Coils originating in mainland Europe shall be placed on anti-slip matting.

3. Pre-loading considerations

- ✓ Well width must be a minimum of 1100mm.
- ✓ Well angle must be a minimum of 30 degrees.
- ✓ Coil well must be dry and clear of debris and other loose items.
- ✓ Coil must be clear of well base by a minimum of 20mm.
- ✓ Well posts must be inspected regularly and be in good condition.
- ✓ Well boards used for blocking must comply with the Technical Information Sheet for well boards - document reference TIS-0006 Well boards for well trailers.

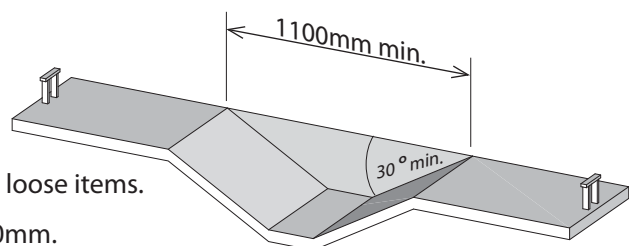

This Load Restraint Guideline is designed to be compliant with the forces specified in EN 12195-1:2003 and VDI 2700.

LOAD RESTRAINT GUIDELINE

Wide coil in well

4. Restraint system with well posts

4.1 General restraint system

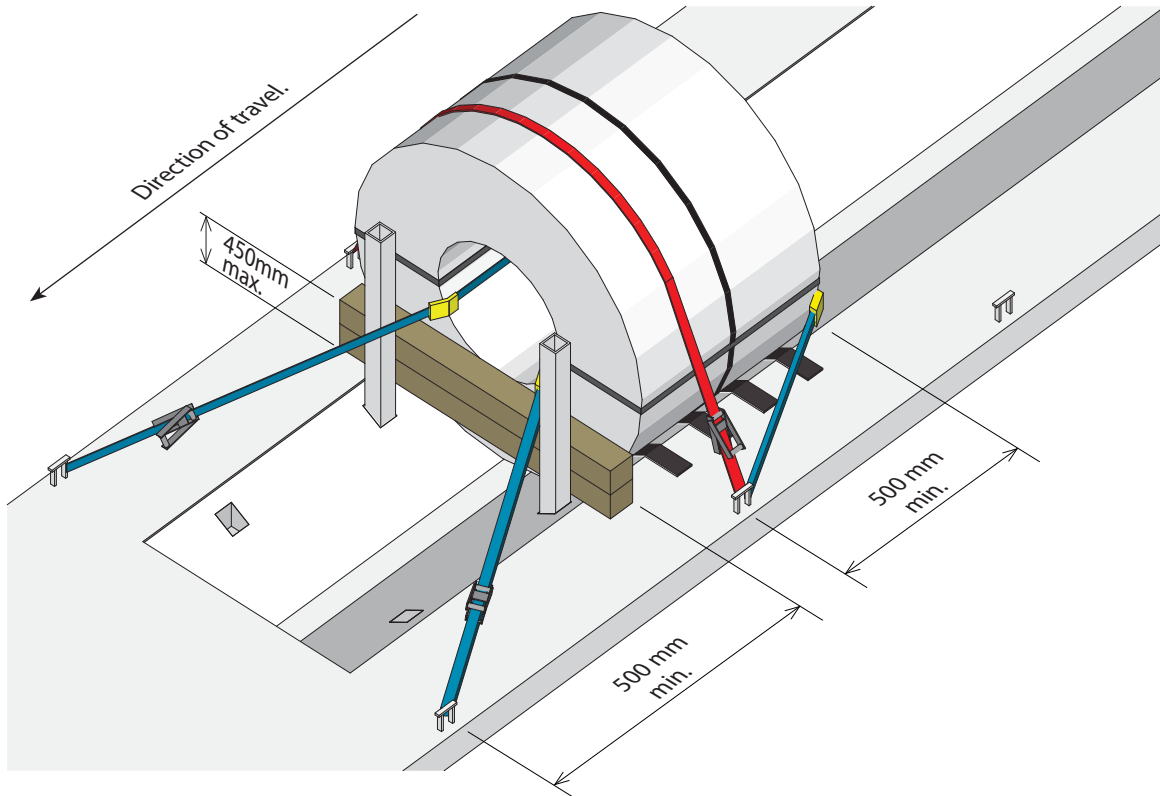

Anti-slip matting shown for coils originating in mainland Europe.

- Valid for **hot rolled coils** (not pickled and oiled) up to **30 tonnes**.
- Valid for **low friction** coils up to **24 tonnes**.
- **Low friction** coils above **24 tonnes** must be restrained with **2500 daN bore straps**, anchored a minimum of 1000mm from the front and rear faces of the coil. Alternatively, an additional pair of 2000 daN **straps** may be fitted through the bore, provided they are attached to different anchor points.

- ✓ Timber dunnage stacked between the coil and well posts as blocking (minimum timber size 100 x 100mm).
- ✓ Dunnage must extend beyond outer edges of the trailer well and well posts.
- ✓ Blocking should be up to the base of the coil bore, but not exceed 450mm.
- ✓ Maximum gap of 20mm between coil base and choice of blocking.
- ✓ Where timber dunnage cannot be used, steel well posts may be substituted as blocking with anti-slip matting between the horizontal faces of the steel posts.
- ✓ **1 strap** over-the-top.
- ✓ Well boards may also be used in the upright position as a form of blocking between the vertical well posts and coil, provided they are compliant with TIS-0006.
- ✓ **2 straps** through the bore pulling forward with the ratchets positioned as shown above.
- ✓ **Bore straps** to be anchored a minimum of 500mm from front and rear faces of coil.

Note 1: Coefficient of static friction between as-rolled coil and anti-slip matting is taken to be 0.6.
Coefficient of static friction between as-rolled coil and wood / rubber lined well is taken to be 0.4.
Testing the worst-case low-friction coil confirmed a coefficient of static friction of 0.3.

LOAD RESTRAINT GUIDELINE

Wide coil in well

4.2 Option for coils up to 1300mm outside diameter - placed directly against well posts

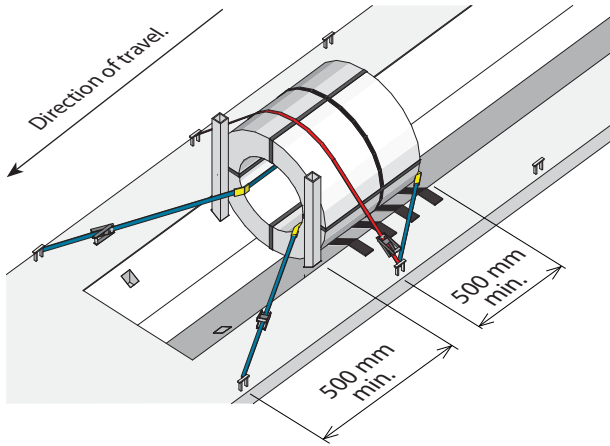

- ✓ Coil diameter extends beyond the outer edges of the well post.
- ✓ Maximum gap of 20mm between coil base and well posts.
- ✓ 1 strap over-the-top.
- ✓ 2 straps through the bore pulling forward with the ratchets positioned as shown.
- ✓ Bore straps to be anchored a minimum of 500mm from front and rear faces of coil.

Anti-slip matting shown for coils originating in mainland Europe .

- For coils with an outside diameter greater than 1300mm, refer to Section 4.1 or Section 5 as appropriate.
- Where coil diameter does not extend beyond outer edges of well posts, refer to Section 4.1 or Section 5 as appropriate.

5. Restraint system without well posts

Low friction coils - maximum coil weight **10 tonnes**

Hot rolled coils (not pickled and oiled) - maximum coil weight **16 tonnes**

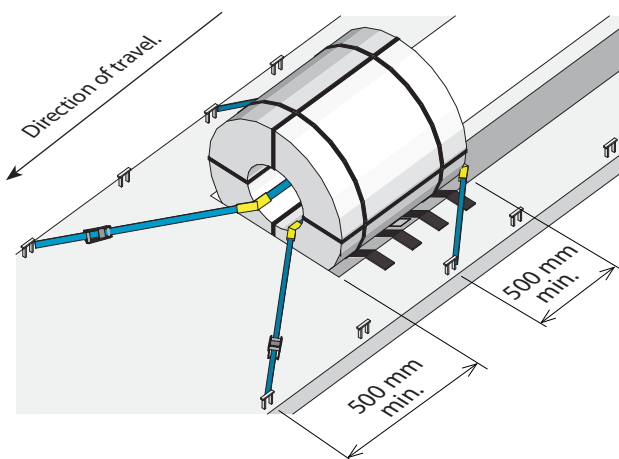

- ✗ Not for topple sensitive coils. All topple sensitive coils must be restrained as shown in Section 4.1.
- ✓ Coil must be positioned up against the front of the well to provide forward restraint.
- ✓ 2 straps through the bore pulling forward with the ratchets positioned as shown.
- ✓ Bore straps to be anchored a minimum of 500mm from front and rear faces of coil.

Anti-slip matting shown for coils originating in mainland Europe .

LOAD RESTRAINT GUIDELINE

Wide coil in well

6. Other loading considerations

6.1 Loading multiple coils

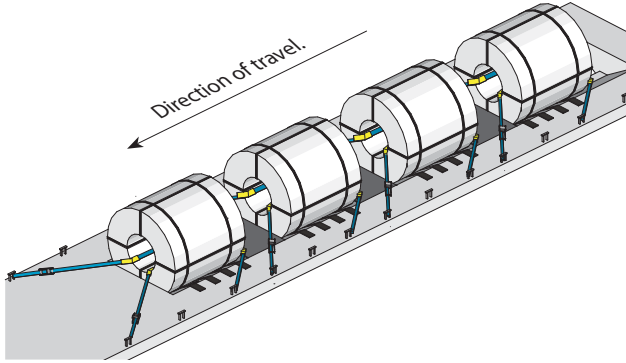

Anti-slip matting shown for coils originating in mainland Europe.

- ✓ Front coil placed against front of well (or against well posts as per Sections 4.1).
- ✓ Non-topple sensitive coils restrained as shown in Section 5.
- ✓ No more than ONE well board to be placed in the well between coils as blocking.
- ✓ Individual coils must not exceed 10 tonnes in weight.

Note 2: Topple sensitive coils, or coils above 10 tonnes, must be restrained individually against well posts as shown in Sections 4.1 and 4.2.

6.2 Lashing points

- Maximum of 2 straps per lashing point and lashings must be pulling in opposite directions.
- Strap for rearward restraint may be applied to the same lashing point as the over-the-top strap for this guideline.
- Webbing straps to the same lashing point must NOT be acting in the same direction.

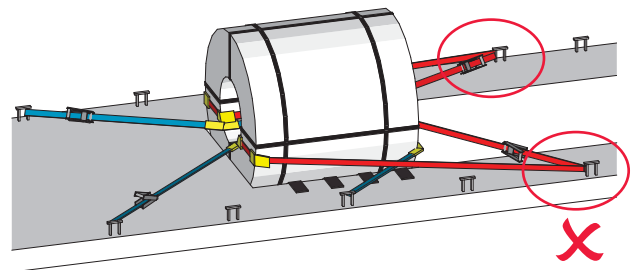
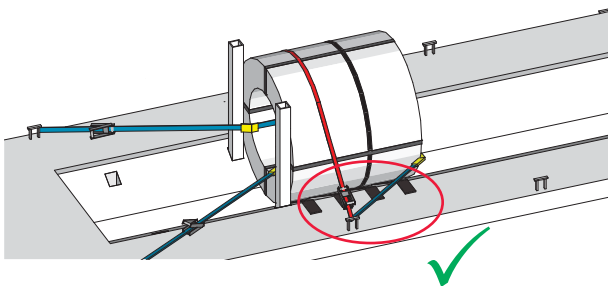

6.3 Anti-slip matting

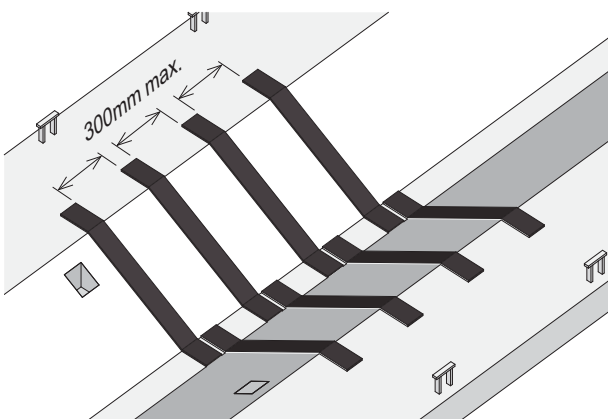

- ✓ Anti-slip matting must be a minimum of 8mm thick.
- ✓ Maximum of 300mm space between each strip of matting.
- ✓ Anti-slip matting must span the full width of the coil well with some overlap, so as to remain visible once coil is placed into well.
- ✗ Conveyor belt is NOT a form of anti-slip matting.
- ✗ Anti-slip matting must not be used as a form of edge protection.

Care has been taken to ensure that the contents of this publication are accurate, but Tata Steel Europe Limited and its subsidiaries do not accept responsibility or liability for errors or information that is found to be misleading.

ROAD REGULATION GUIDELINE

Horizontal coils on cradles

This guideline applies to

- Horizontal coils - weight: 0 - 10 tons
- Coils placed on Tata Steel specification cradles

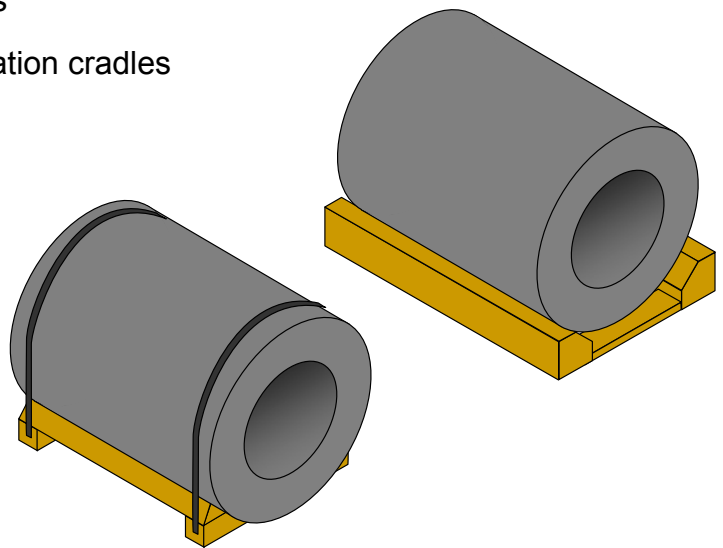

Requirements per coil

- Flat loading platform
- Tata cradle if necessary
- 4 Securing points
- 2 Straps:
 - lashing capacity (LC) ≥ 2000 daN
- 3 Ratchets:
 - lashing capacity (LC) ≥ 2000 daN
 - standard tension force (STF) ≥ 300 daN
- 6 Edge protectors
- Sufficient anti-slip mats (minimum of 6 mats)

Preparation

- Place the anti-slip mats on the loading platform at the point the coil should be loaded, next to a securing point.
 - The amount of anti-slip mats must be adapted to make sure there is no direct contact between the coil and the loading platform, even after a small movement of the cradle.
 - The use of anti-slip mats between cradle and loading platform is not mandatory when the cradle has a solid connection to the loading platform.
- Place the loose cradle on the anti-slip mats so the coil can be loaded with the eye of the coil at right angles to the driving direction.
- No cradles have to be made ready for Tata Steel coils that are already packed with a cradle.

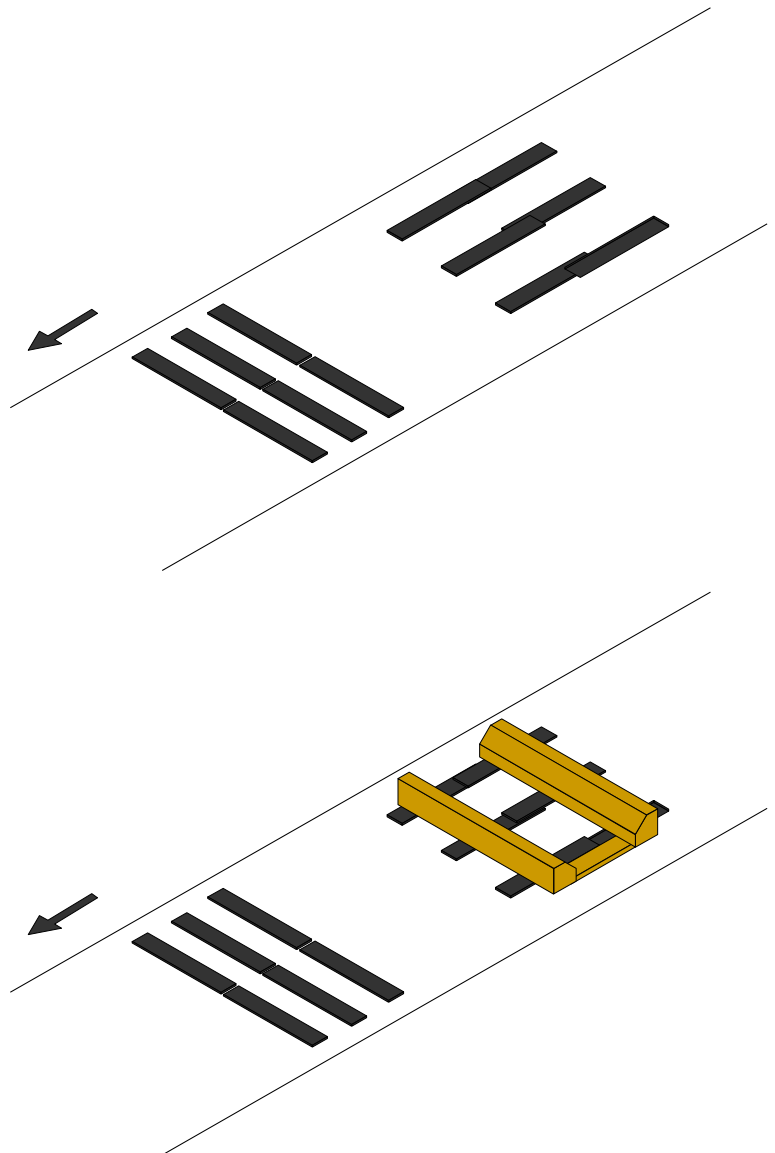

Loading

- The coil will be loaded on the loose cradle with the eye of the coil at right angles to the driving direction.
- A coil with a Tata Steel cradle will be loaded on the anti-slip mats with the eye of the coil at right angles to the driving direction.
- To protect the coil anti-slip mats must be used between the cradle and the coil when the cradle is made of steel.

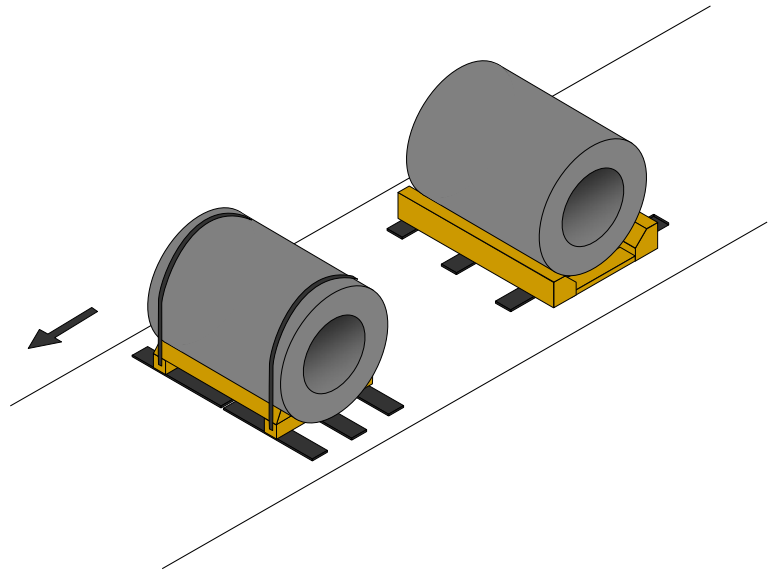

Securing

- The first strap runs from a securing point at the back of the coil through the eye of the coil in a U-formation to a securing point at the back of the coil on the opposite side of the trailer.
 - The ends of the strap must have an angle of 45° or less, slantwise to the back, compared to the driving direction.
 - Edge protectors must be used between the edges of the coil and the strap where necessary.

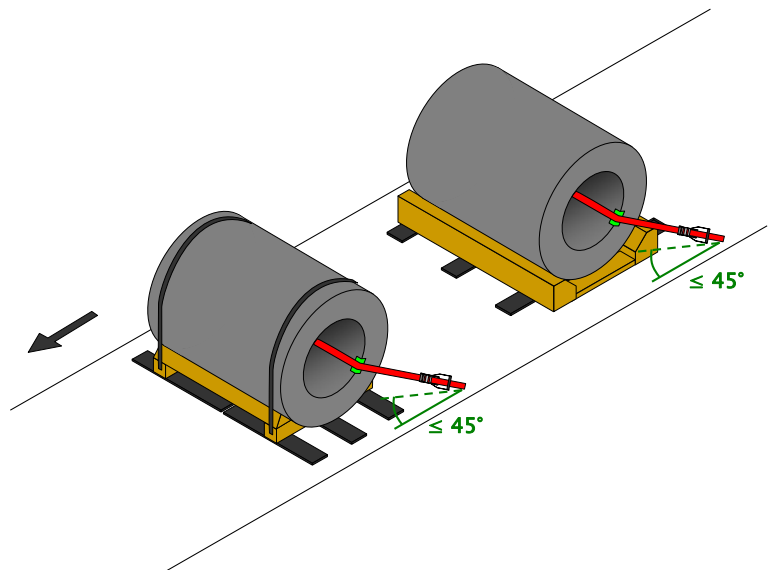

- The second strap must be put through the ratchet and pulled almost to the end.
- The second strap runs from a securing point next to the coil, over the coil, back through the eye of the coil and again over the coil to a securing point next to the coil on the opposite side of the trailer.
- The second strap should now have a ratchet on each end of the strap and must be tightened with these two ratchets.
- Edge protectors must be used between the edges of the coil and the strap.

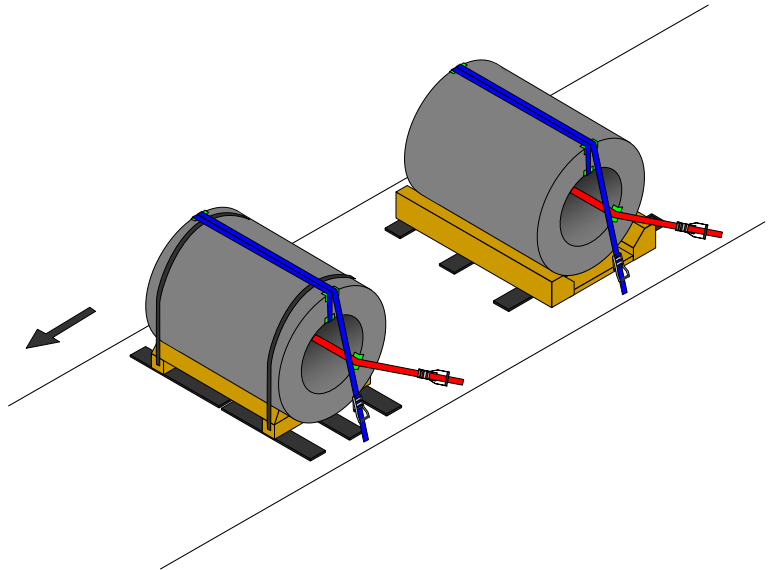

- As an option a third strap may be added in a U form and secured in front of the coil.

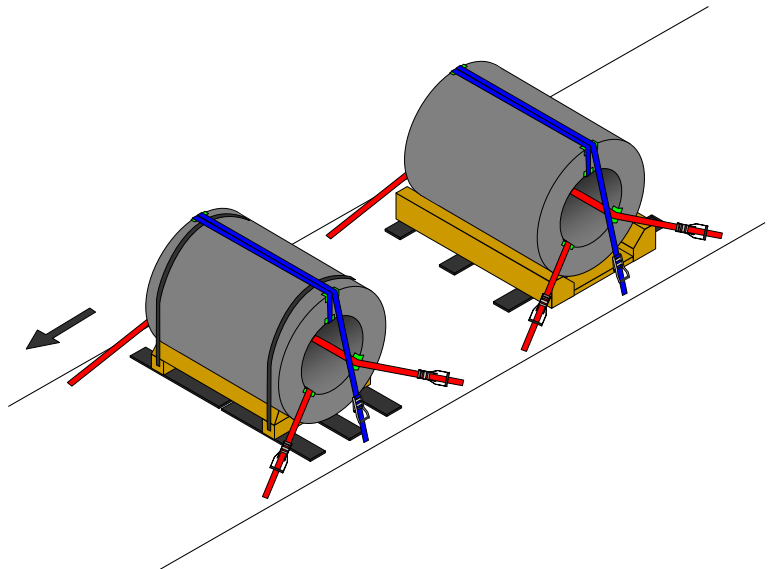

- The load restraint method described in this document is designed to be compliant with the forces as specified in EN12195-1: 2003 and VDI 2700.

ROAD REGULATION GUIDELINE

Horizontal coils on stillages

This guideline applies to

- Horizontal coils - weight: 0 - 10 tons
- The method with stillages is to be used only in combination with blocking in forward direction

Requirements per coil

- Flat loading platform
- Minimum of 2 stillages
- 4 Securing points
- 2 Straps:
 - lashing capacity (LC) ≥ 2000 daN
- 3 Ratchets:
 - lashing capacity (LC) ≥ 2000 daN
 - standard tension force (STF) ≥ 300 daN
- 6 Edge protectors
- Sufficient anti-slip mats (minimum of 6 mats)

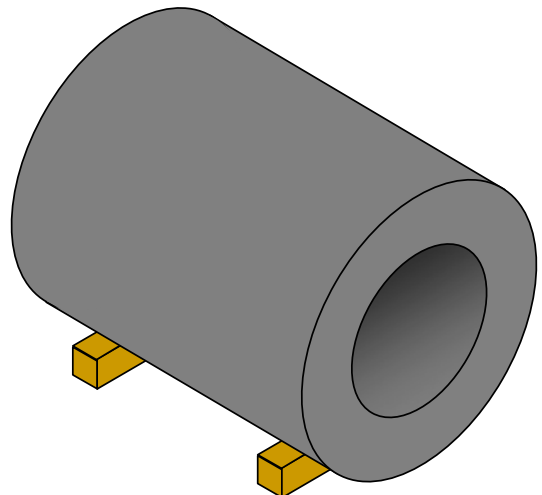

Preparation

- Place the anti-slip mats on the loading platform at the point the coil should be loaded, next to a securing point.
 - The amount of anti-slip mats must be adapted to make sure there is no direct contact between the coil and the loading platform, even after a small movement of the stillages.
 - The use of anti-slip mats between stillages and loading platform is not mandatory when the stillages have a solid connection to the loading platform.
- Place the stillages on the anti-slip mats so the coil can be loaded with the eye of the coil at right angles to the driving direction.
- No stillages have to be put ready for Tata Steel coils that are already packed with a cradle.

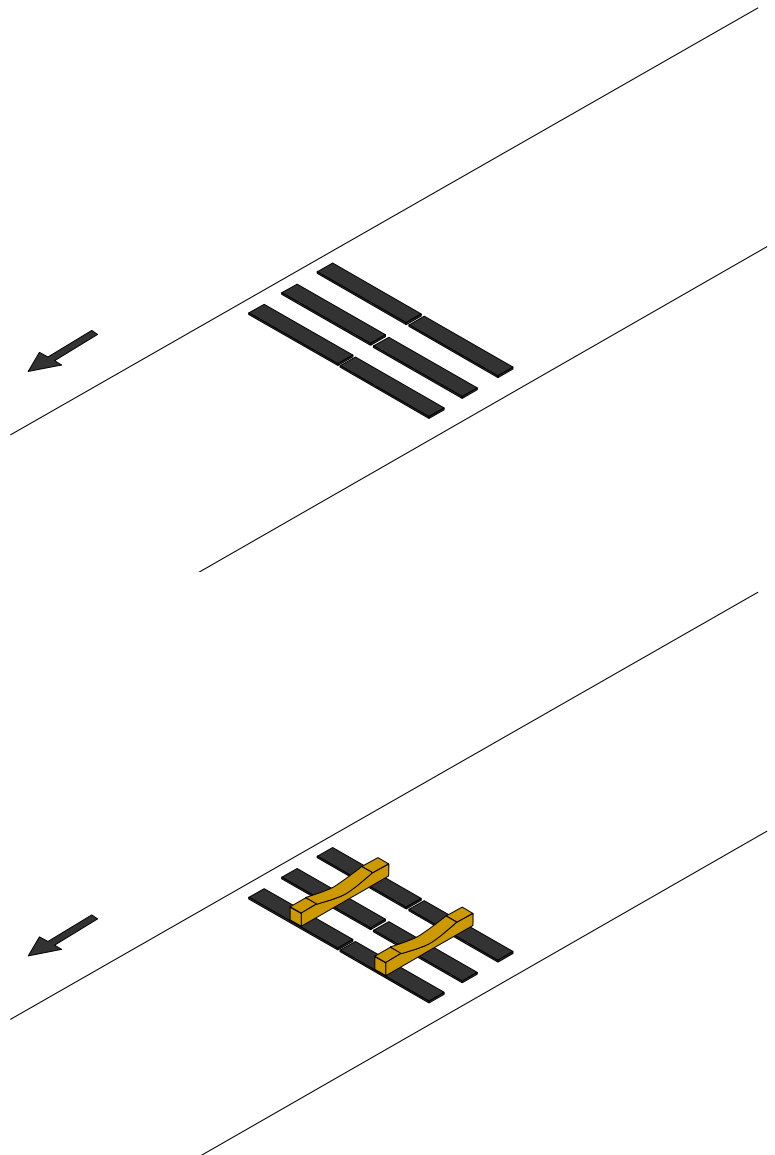

Loading

- The coil will be loaded on the stillages with the eye of the coil at right angles to the driving direction.

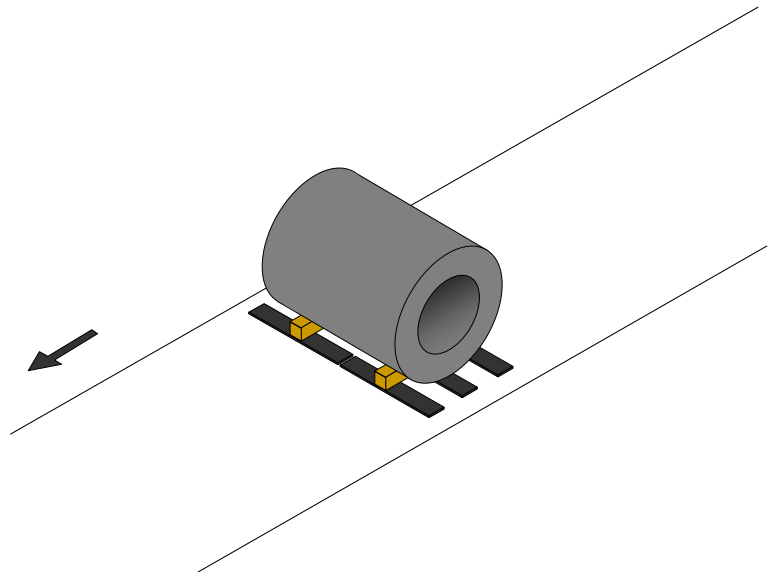

Securing

- The first strap runs from a securing point at the back of the coil through the eye of the coil in a U-formation to a securing point at the back of the coil on the opposite side of the trailer.
 - The ends of the strap must have an angle of 45° or less, slantwise to the back, compared to the driving direction.
 - Edge protectors must be used between the edges of the coil and the strap where necessary.

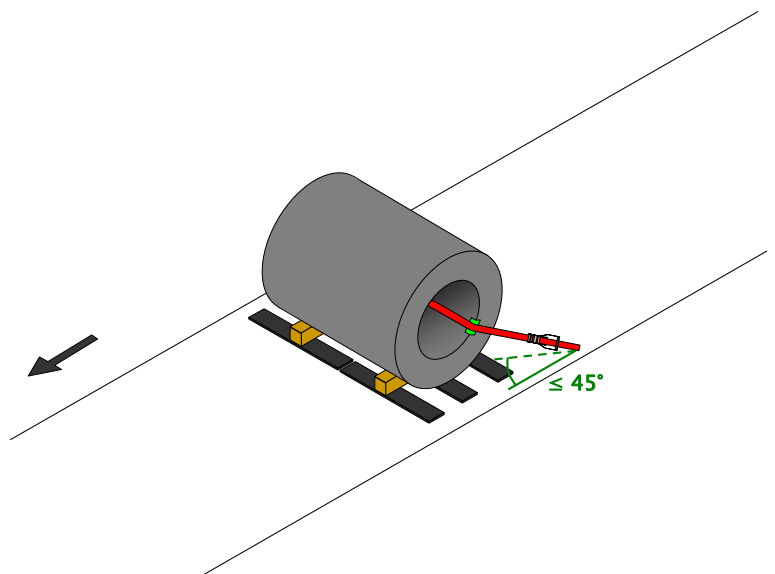

- The second strap must be put through the ratchet and pulled almost to the end.
- The second strap runs from a securing point next to the coil, over the coil, back through the eye of the coil and again over the coil to a securing point next to the coil on the opposite side of the trailer.
- The second strap should now have a ratchet on each end of the strap and must be tightened with these two ratchets.
- Edge protectors must be used between the edges of the coil and the strap.

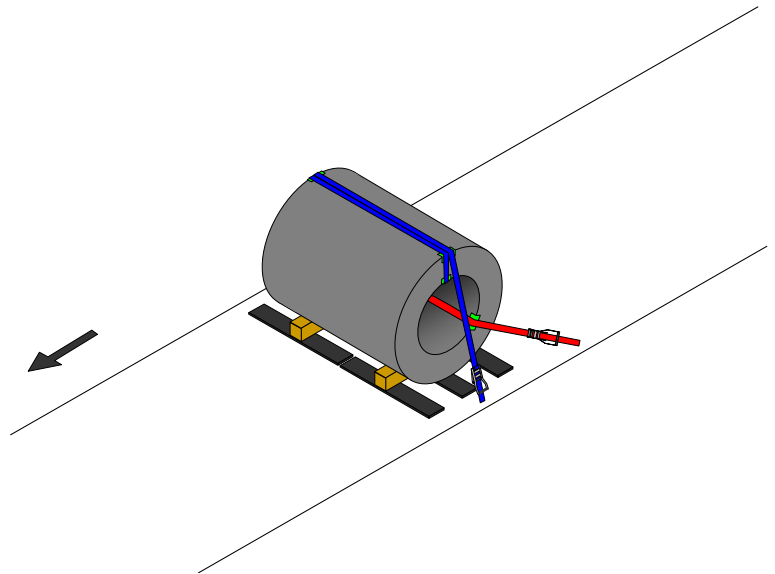

- As an option a third strap may be added in a U form and secured in front of the coil.

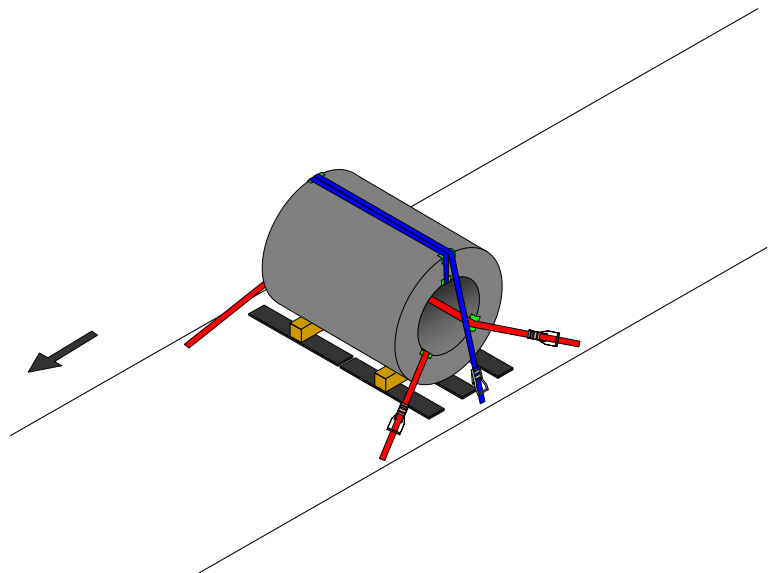

- The load restraint method described in this document is designed to be compliant with the forces as specified in EN12195-1: 2003 and VDI 2700.

ROAD REGULATION GUIDELINE

Rest coil on flat loading platform

This guideline applies to

- Coils – weight: 0 - 4 tonnes
- Coils where chains may be used (2nd choice for example)

Requirements per 3 - 5 coils

- 4 Securing points
- 2 chains conform EN 12195-3: 2001:
 - lashing capacity (LC) ≥ 3000 daN
- 2 Tensioners conform EN 12195-2: 2001:
 - lashing capacity (LC) ≥ 3000 daN
- 1 Wedge

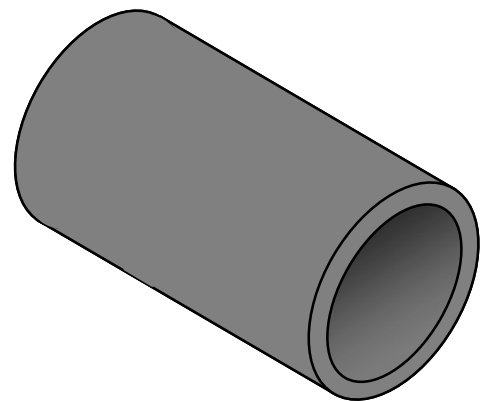

Requirements per load rest coils

- Set of stanchions
- Trailer with 30 cm high sideboards is preferred.
- Wooden loading platform.
- Sufficient anti-slip mats must be used when the loading platform is made of another material.

Preparation

- The stanchions must be placed in the well and the well must be fully covered.
- Anti-slip mats must be placed on the loading platform from the stanchions to the back when the loading platform is not made of wood.
 - The number of anti-slip mats must be adapted to make sure there is no direct contact between the coils and the loading platform.

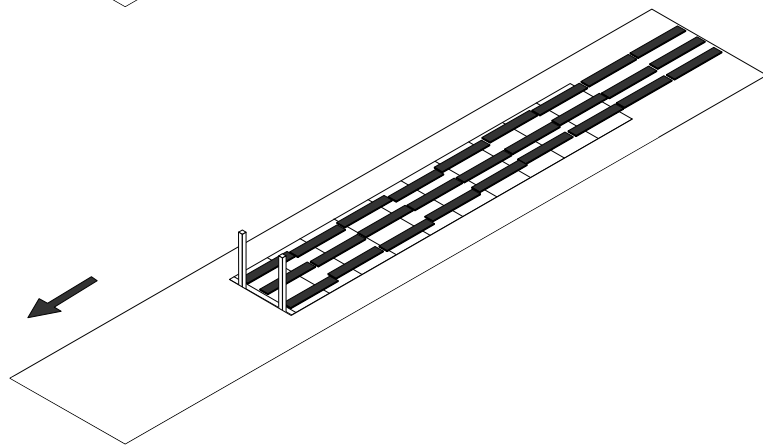
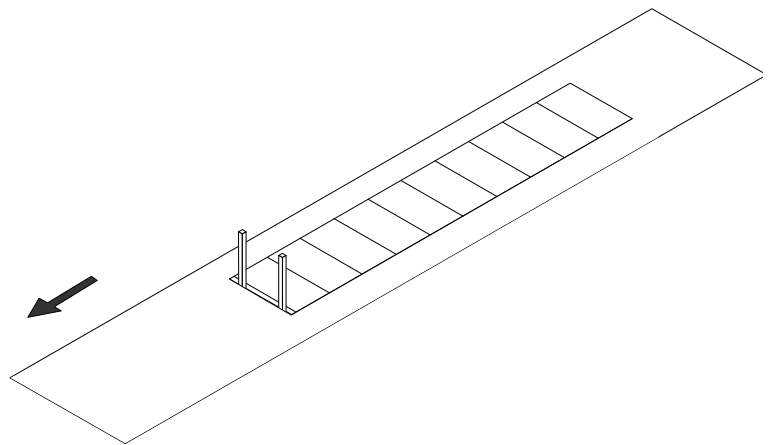

Loading

- The coils will be loaded in groups of 3 to 5 coils depending on axle weights. During loading this must be taken into account.
 - The first coil must be placed directly against the stanchions. No space must be left between so the coils are locked in forward direction.

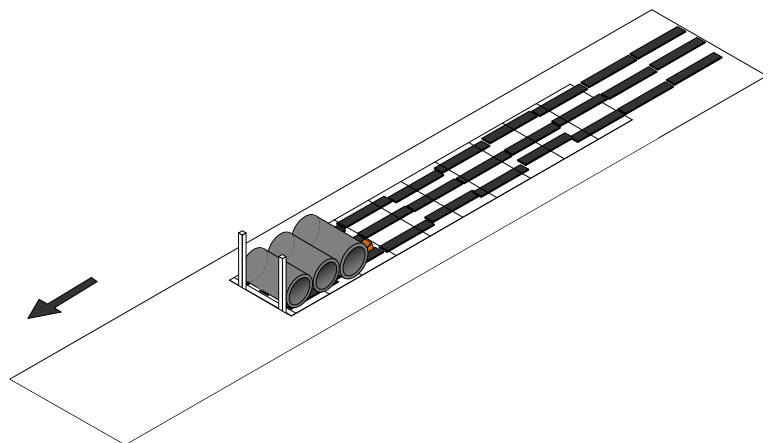

- The diameter of the first and last coil of a group must be the same or larger than the diameter of the intermediate coils to prevent the intermediate coils being pressed upwards when securing the coils.
- Groups should be as small as possible.
- A wedge is placed at the back of the last coil of the group and positioned with care to prevent shifting of the group.
- Repeat this step for each group until all the coils are loaded.

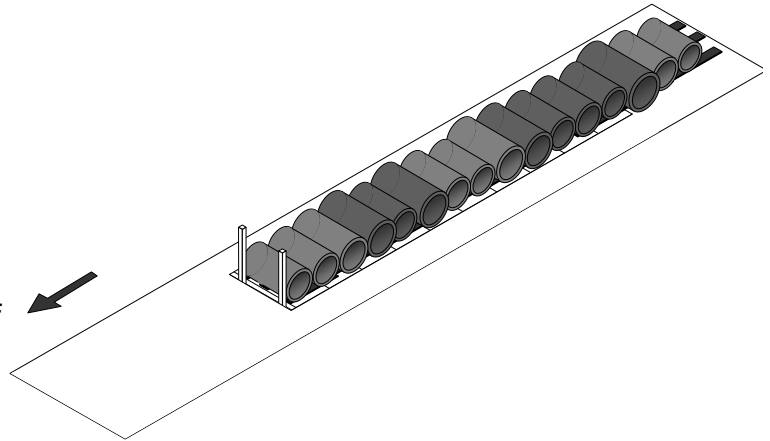

Securing

- The coils will be secured in groups of 3 to 5 coils depending on the positioning and number of securing points.
- The first chain runs from a backward lying securing point in a U-formation through the eye of the coil, to a securing point on the opposite site of the trailer.
- The second chain runs from a forward lying securing point in a U-formation through the eye of the coil, to a securing point on the opposite site of the trailer.

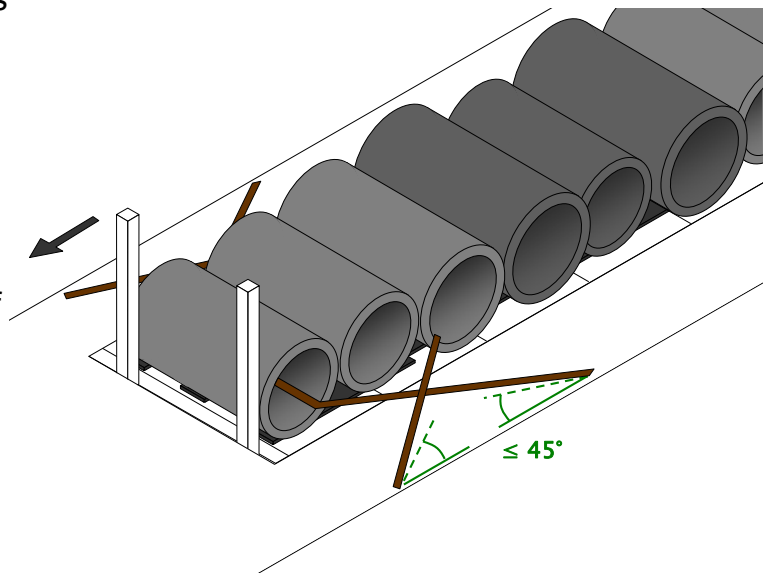

- The ends of the chain must have an angle of 45° or less compared to the driving direction.
- The chains must always pass along the front of the intervening coils
- Repeat this step for each group until no group of minimal 3 coils remains.

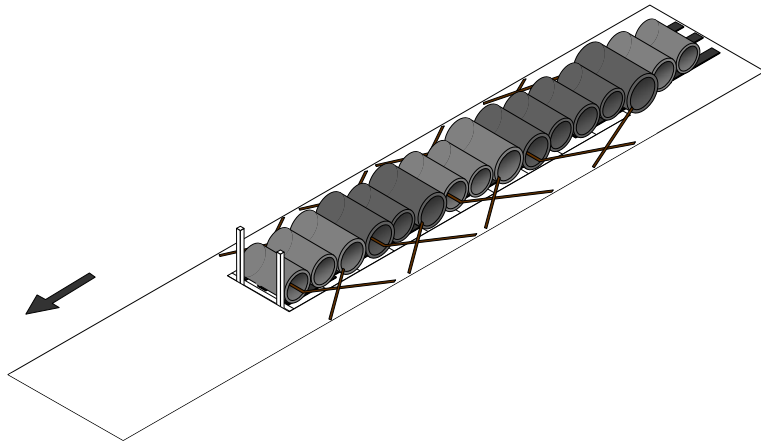

- Any remaining coils should be secured as follows:
 - One remaining coil is tightened against the other coils.

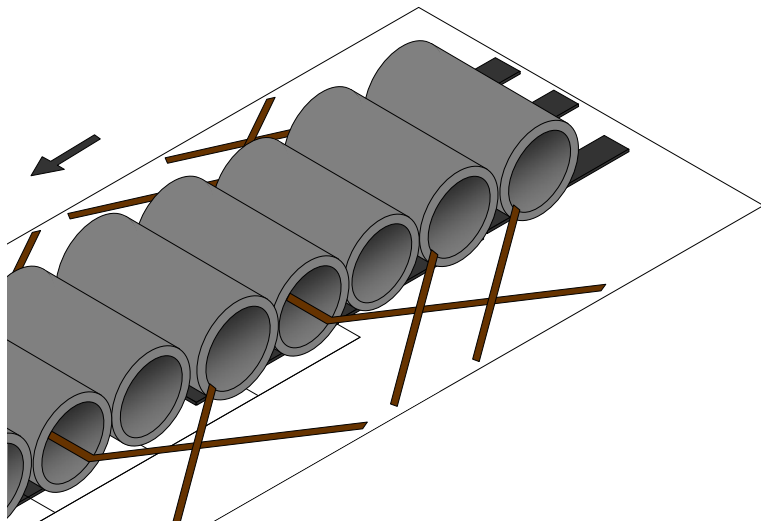

- Two remaining coil are secured similar to a group but without intervening coils.

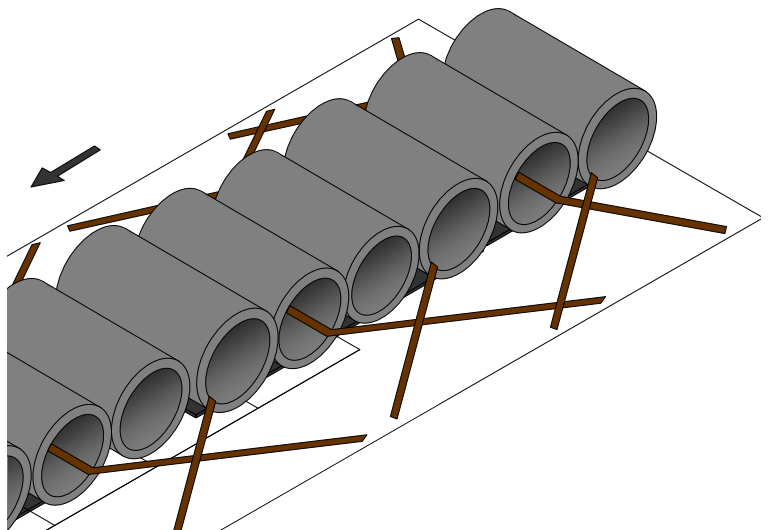

- The load restraint method described in this document is designed to be compliant with the forces as specified in EN12195-1: 2003 and VDI 2700.

ROAD REGULATION GUIDELINE

Rest coil in well

This guideline applies to

- Damaged collapsed bore horizontal coils a weight of 0 – 25 tonnes
- Where it is not possible or safe to place web lashings through the bore of the coil:

Requirements per coil

- Coil well trailer
- Set of stanchions
- 4 Securing points rated to a minimum of 3000 daN
- 2 Chains conform EN 12195-3: 2001:
 - lashing capacity (LC) ≥ 3000 daN
- 2 Tensioners conform EN 12195-2: 2001:
 - lashing capacity (LC) ≥ 3000 daN
- Anti-slip mat every 30 cm

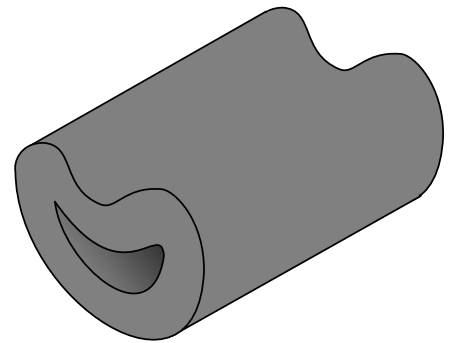

Requirements per narrow coil

- Coil well trailer
- Set of stanchions
- 2 Securing points rated to a minimum of 3000 daN
- 1 Chain conform EN 12195-3: 2001:
 - lashing capacity (LC) ≥ 3000 daN
- 1 Tensioners conform EN 12195-2: 2001:
 - lashing capacity (LC) ≥ 3000 daN
- Anti-slip mat every 30 cm

Preparation

- Open the well about a meter more than the width of the coil.
- Place the stanchions in the well.
- Place the anti-slip mats in the well at the point the coil will be loaded.
 - The number of anti-slip mats must be adapted to make sure that there is no direct contact between the coil and the well, an anti-slip mat must be placed at least every 30 cm.
 - Place the anti-slip mats so that they are still visible when the coil is loaded.

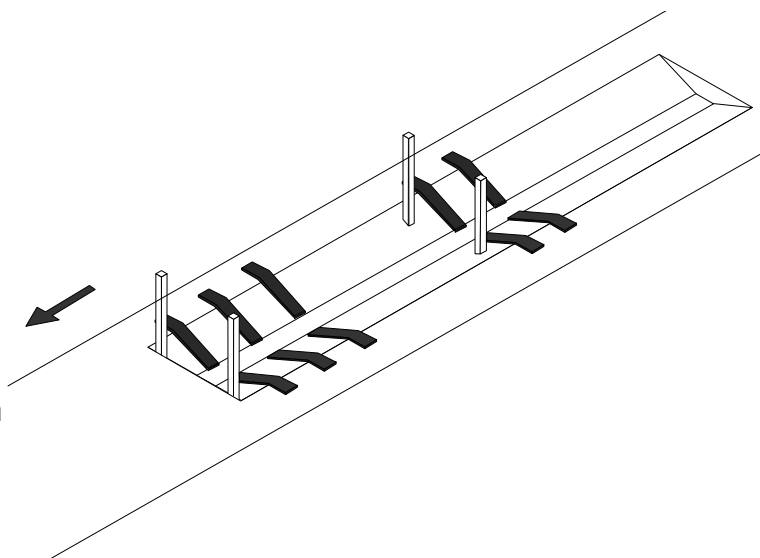

Loading

- The coil will be loaded on the anti-slip mats in the well.
- The coil must be placed directly against the stanchions. No space must be left between so the coils are locked in forward direction.

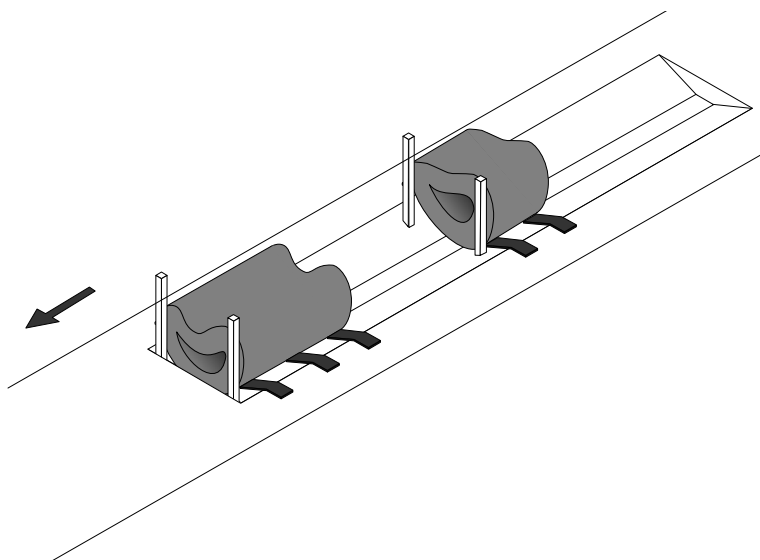

Securing

- The coil must be secured with at least two chains over the top of the coil. A cross is formed by letting these two chains run diagonal from one side of the trailer to the opposite site.
- It is not always possible to form a cross over narrow coils. A narrow coil must be secured with one chain over the top of the coil.

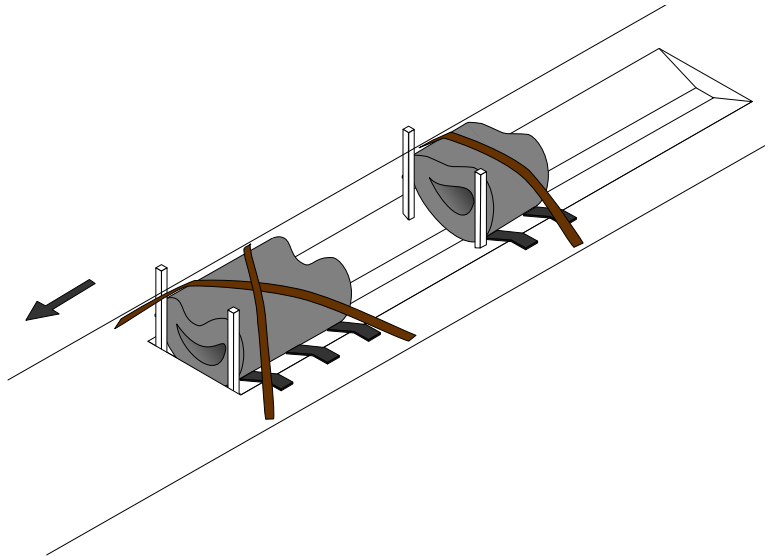

- The load restraint method described in this document is designed to be compliant with the forces as specified in EN12195-1: 2003 and VDI 2700.

Blank page

ROAD REGULATION GUIDELINE

Coil bore vertical (ETTS)

This guideline applies to

- ETTS coils with a weight of 0 - 14 tonnes
- Coils are packaged onto plastic skids or specially designed wooden pallets coil weight:
- Wooden pallets are to have a mounting boss in the bore of the coil.

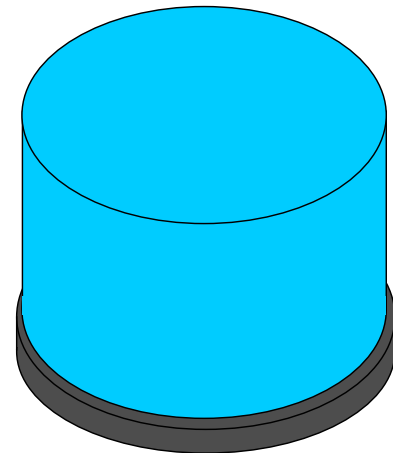

Requirements per coil

- 6 Securing points rated to a minimum of 2000 daN
- 3 Straps conform EN 12195-2: 2001:
 - lashing capacity (LC) ≥ 2000 daN
- 3 Ratchets conform EN 12195-2: 2001:
 - lashing capacity (LC) ≥ 2000 daN
 - standard tension force (STF) ≥ 300 daN
- Minimum of 4 anti-slip mats

Preparation

- Place the anti-slip mats on the loading platform at the point the coil should be loaded.
- 6 Securing points are necessary for the securing of one coil. Place the anti-slip mats in the middle between the 4 foremost securing points.
- Place the anti-slip mats in longitudinal direction on the loading platform.

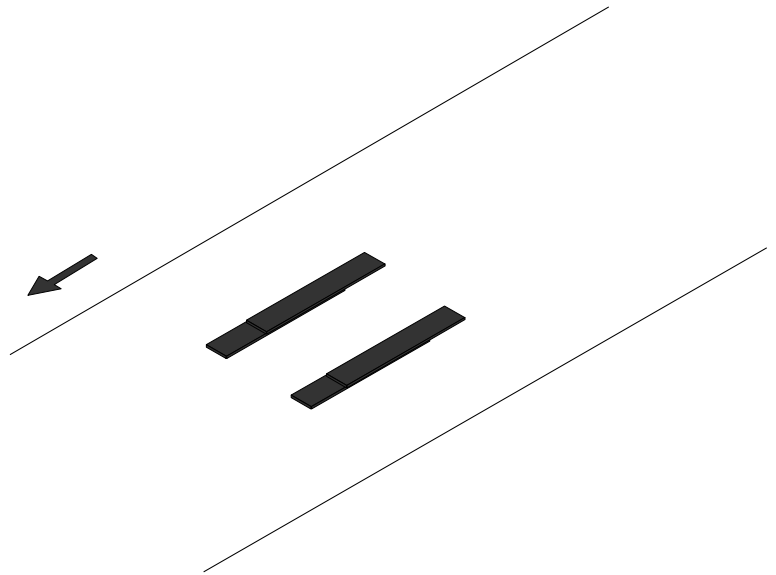

Loading

- The coil will be loaded in the middle of the loading platform on the anti-slip mats.

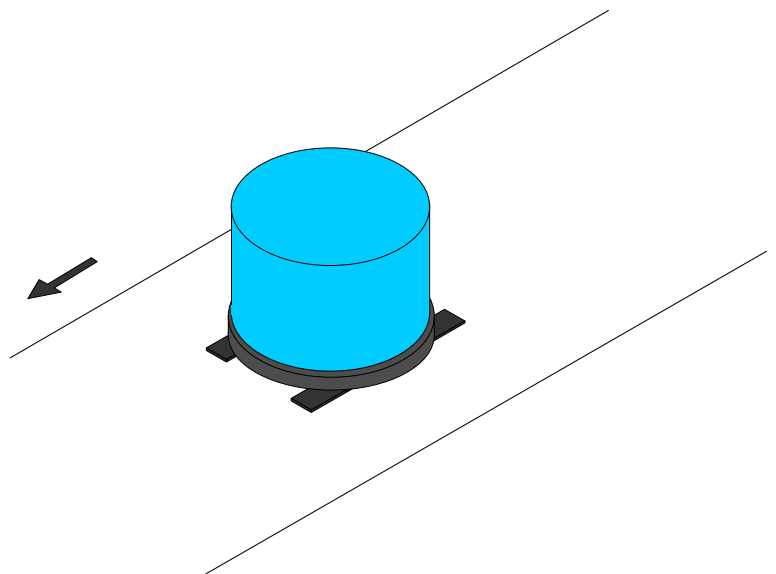

Securing

- Two anti-slip mats are placed parallel to the driving direction on top of the coil.

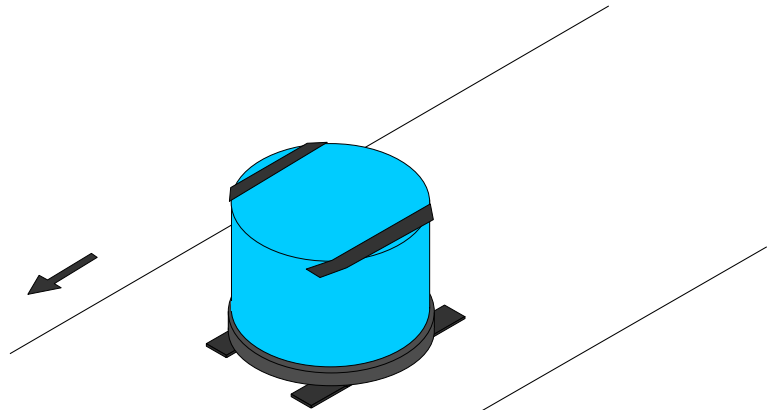

- The first strap runs from the most backward securing points in a U-formation around the base of the coil.

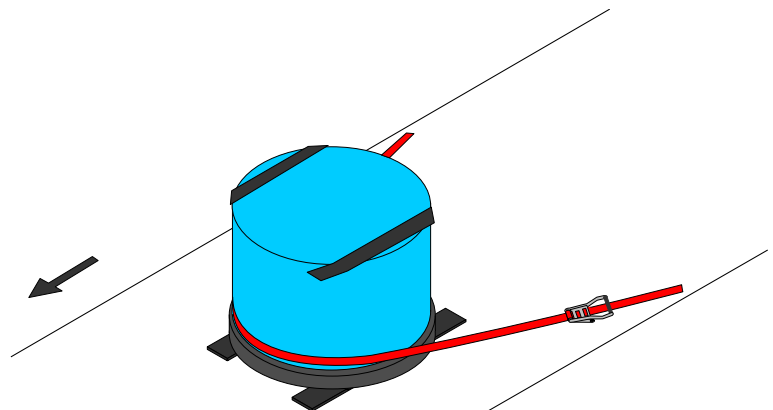

- The second strap is applied in alpha-formation around and over the coil.
 - The hook is attached to the most forward securing point, passed round the back of the coil. Then the strap runs sideways on the friction mat over the coil and along the front of the coil to the securing point on the back side of the trailer.
 - The ratchet must be placed on the rear side of the coil.

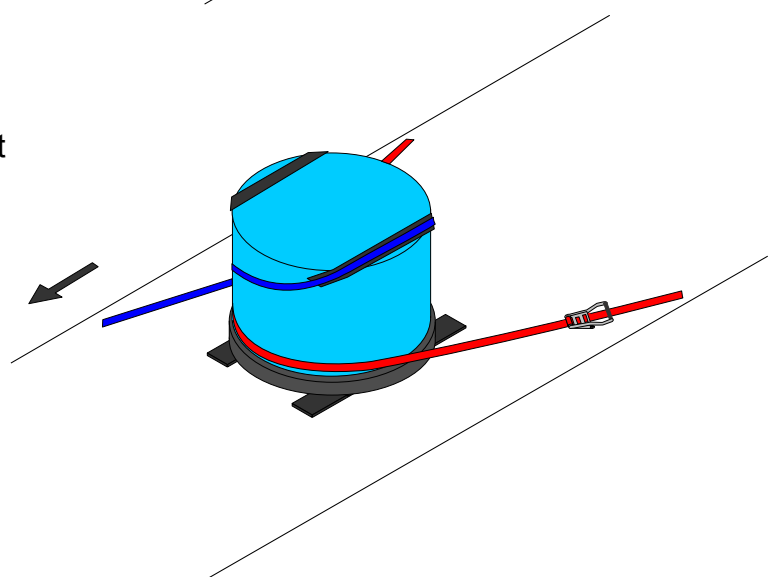

- The third strap is applied in alpha-formation like the second strap, but on the opposite side of the trailer.

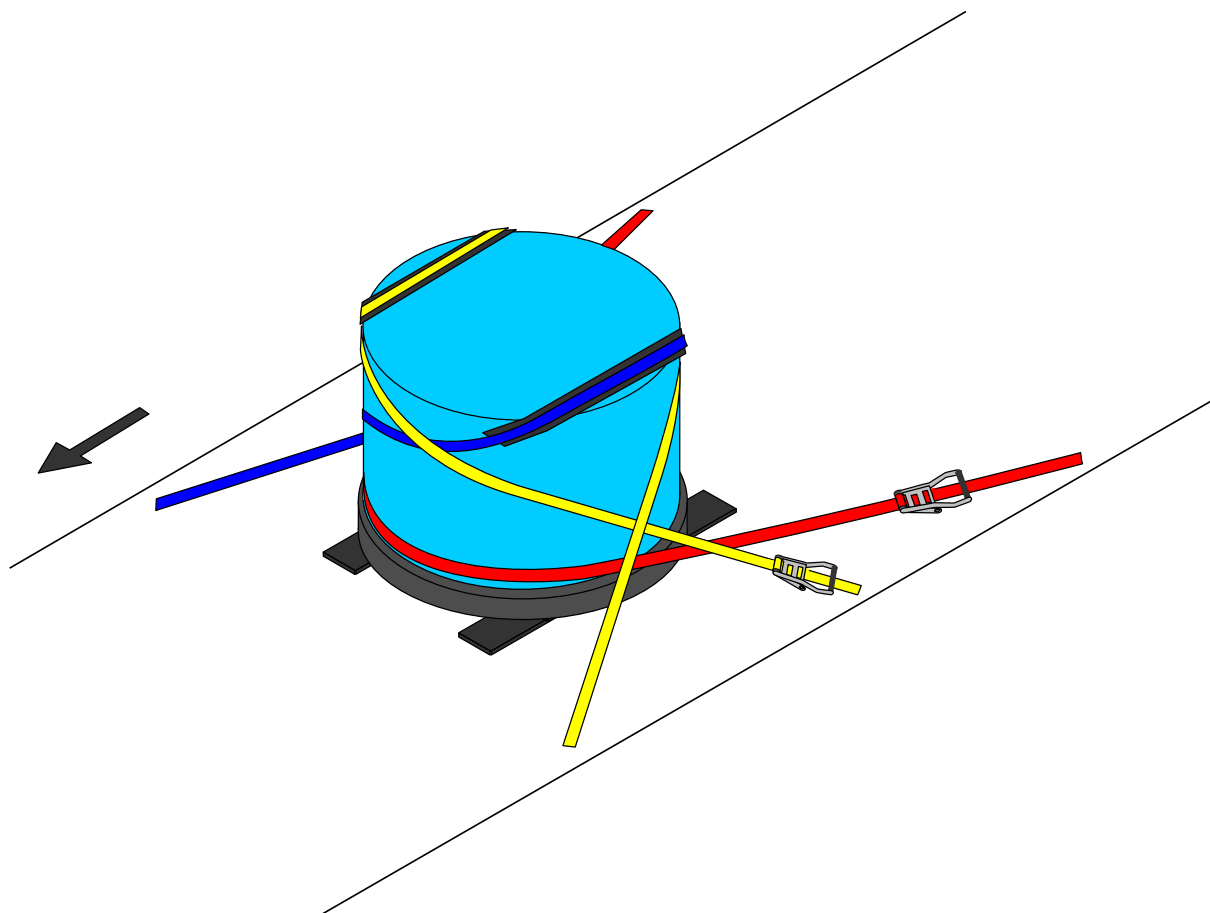

- The ratchet must be placed at the rear side of the coil.
- The load restraint method described in this document is designed to be compliant with the forces as specified in EN12195-1: 2003 and VDI 2700.

ROAD REGULATION GUIDELINE

Vertical slit coils

This guideline applies to

- Slit coils with a weight of 0 - 3 tonnes
- Blocks of coils must not be in excess of 24 tonnes

Requirements per row of slit coils

- 2 Securing points
- 1 Strap:
 - lashing capacity (LC) ≥ 2000 daN
- 1 Ratchet:
 - lashing capacity (LC) ≥ 2000 daN
 - standard tension force (STF) ≥ 300 daN
- 2 Edge protectors
- Sufficient anti-slip mats

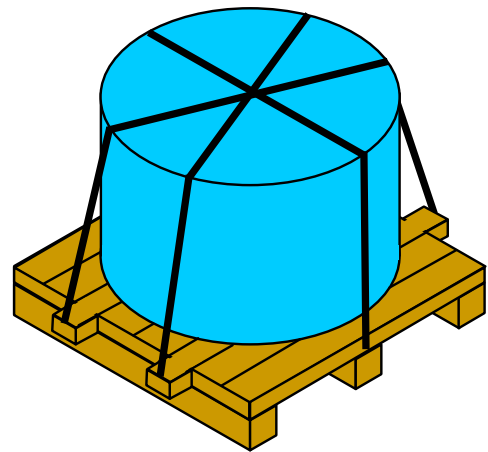

Requirements per block of slit coils

- 2 Securing points
- 1 Strap:
 - lashing capacity (LC) ≥ 2000 daN
- 1 Ratchet:
 - lashing capacity (LC) ≥ 2000 daN
 - standard tension force (STF) ≥ 300 daN

Preparation

- Place the anti-slip mats on the loading platform at the point the coil should be loaded.
- Place the anti-slip mats in longitudinal direction on the loading platform.
- The amount of anti-slip mats must be adapted to make sure there is no direct contact between the coils and the loading platform, even after a small movement of the coils.

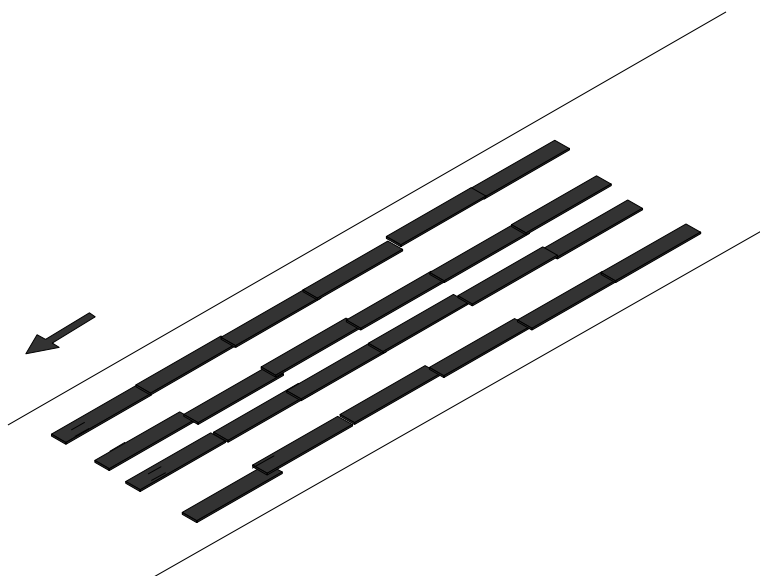

Loading

- The coils will be loaded in pairs in the middle of the loading platform on the anti-slip mats. No space must be left between the products so they are locked in forward direction.
- The coils will be loaded in blocks as large as possible, with a maximum of 24 tons per block.
- When the load consists of an odd number of coils the last row is formed by a single and centrally placed coil.
- Axle weights must be taken into account when placing the coils.

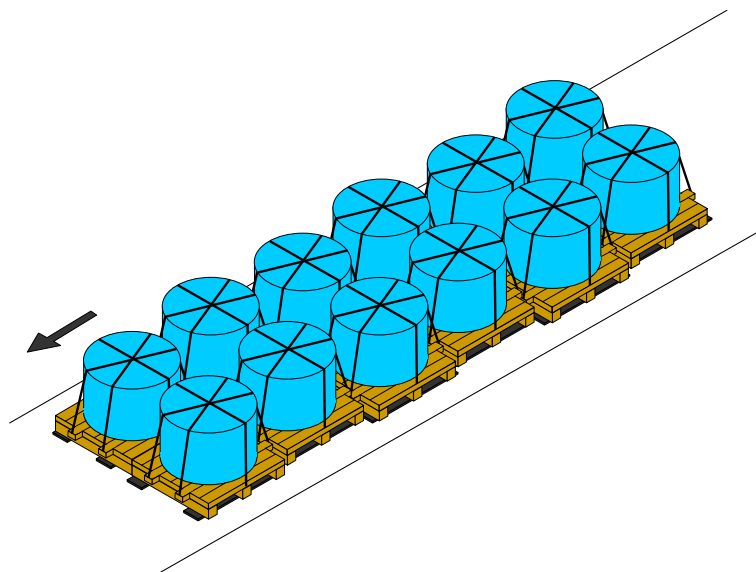

- Axle weights permitting, it is possible to start with a single line of coils from the headboard, going over to a double line.
- The first product must be placed directly against the headboard. No space must be left between so the coils are locked in forward direction.
- It is not permitted to use a single row when the slit coils are placed on round pallets.

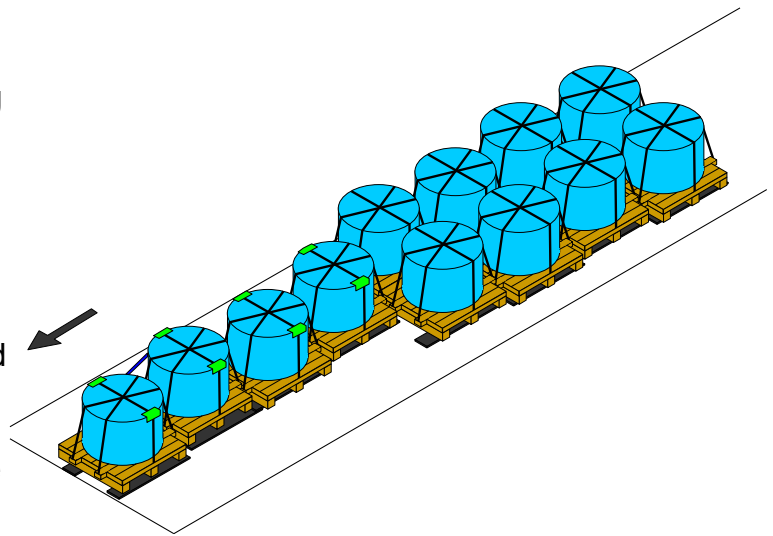

Securing

- Every pair of coils must be secured with at least one strap.
- The straps must be placed over the coils so the straps remain on the coils even after a small movement of the coils.
- Edge protectors must be used between the edges of the coil and the strap.
- A row of single coils is lashed in a similar way as a double row.

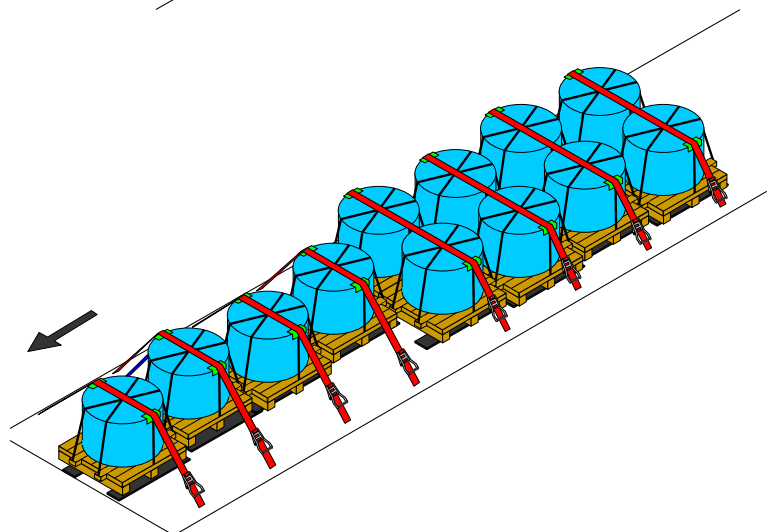
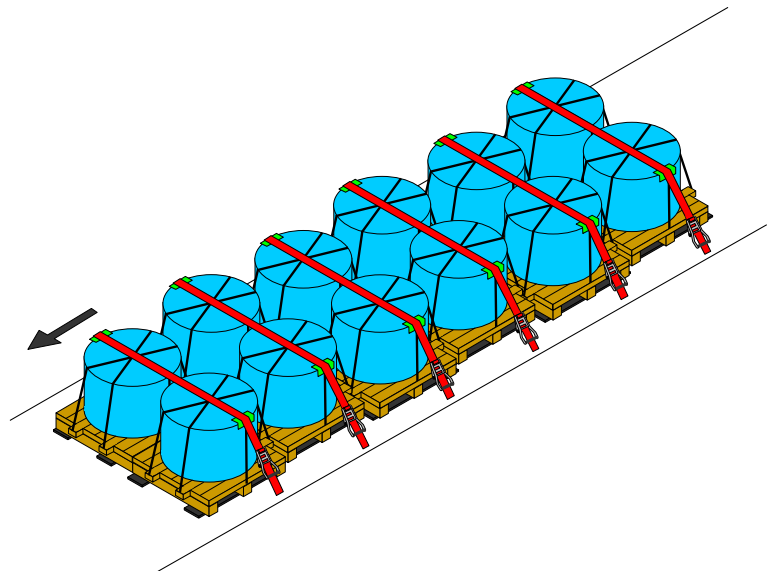

- Every block not placed against the headboard must also be secured with an extra strap.
 - The extra strap runs from a securing point next to the block in a U-formation in front of the block to a securing point on the opposite side of the trailer.
 - The strap must run over the coil just above the pallet.
 - The ends of the strap must be attached as far as possible from the front of the block.

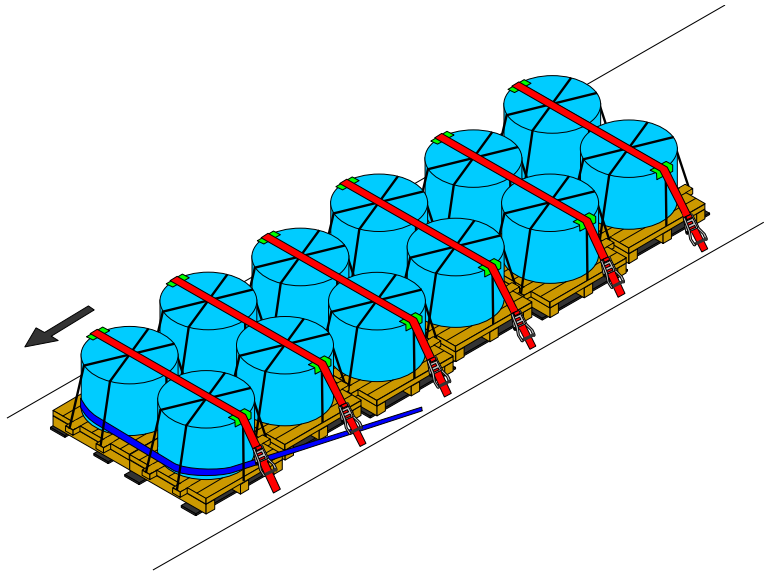

- The load restraint method described in this document is designed to be compliant with the forces as specified in EN12195-1: 2003 and VDI 2700.

ROAD REGULATION GUIDELINE

Tinplate sheet packs

This guideline applies to

- Bundles with a weight of 0 - 3 tonnes
- Blocks of bundles must not be in excess of 25 tonnes:

Requirements per row

- 2 Securing points
- 1 Strap:
 - lashing capacity (LC) ≥ 2000 daN
- 1 Ratchet:
 - lashing capacity (LC) ≥ 2000 daN
 - standard tension force (STF) ≥ 300 daN
- 2 Edge protectors
- Sufficient anti-slip mats

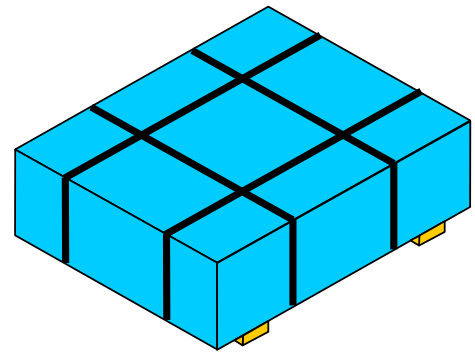

Requirements per block of bundles

- Stanchions or headboard or:-
- 4 Securing points
- 2 Straps:
 - lashing capacity (LC) ≥ 2000 daN
- 2 Ratchets:
 - lashing capacity (LC) ≥ 2000 daN
 - standard tension force (STF) ≥ 300 daN
- 6 Edge protectors

Preparation

- The stanchions must be placed in the well if necessary and the well must be fully covered.
 - Line up the well boards directly against the stanchions, no space must be left between.
- Place the anti-slip mats on the loading platform at the point the bundles should be loaded.
 - Place the anti-slip mats in longitudinal direction on the loading platform.
 - The amount of anti-slip mats must be adapted to make sure that there is no direct contact between the bundles and the loading platform even after a small movement of the bundles.

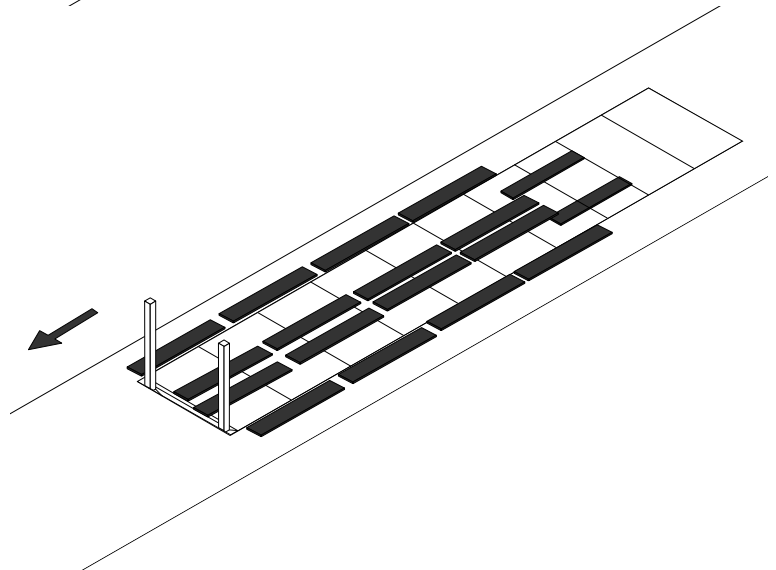
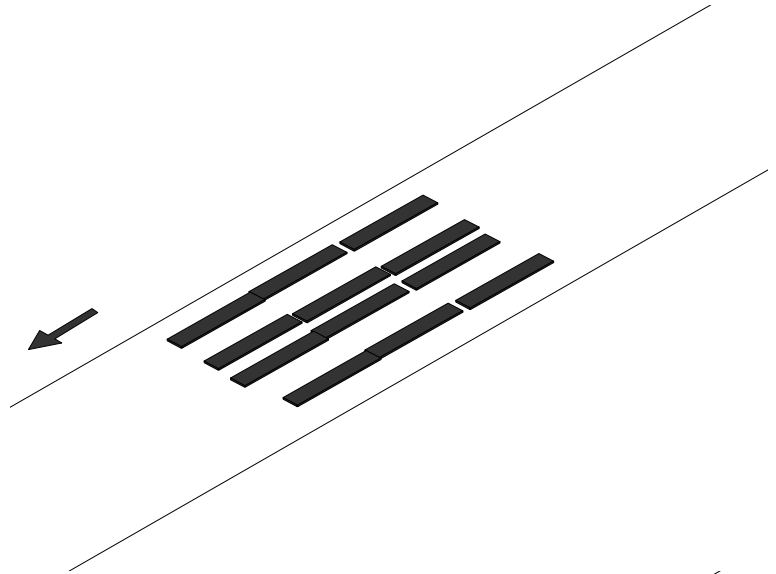

Loading

- The bundles will be loaded in pairs in the middle of the loading platform on the anti-slip mats. No space must be left between the bundles so the bundles are locked in forward direction.
 - The first pair of each block must be placed centred next to a securing point.

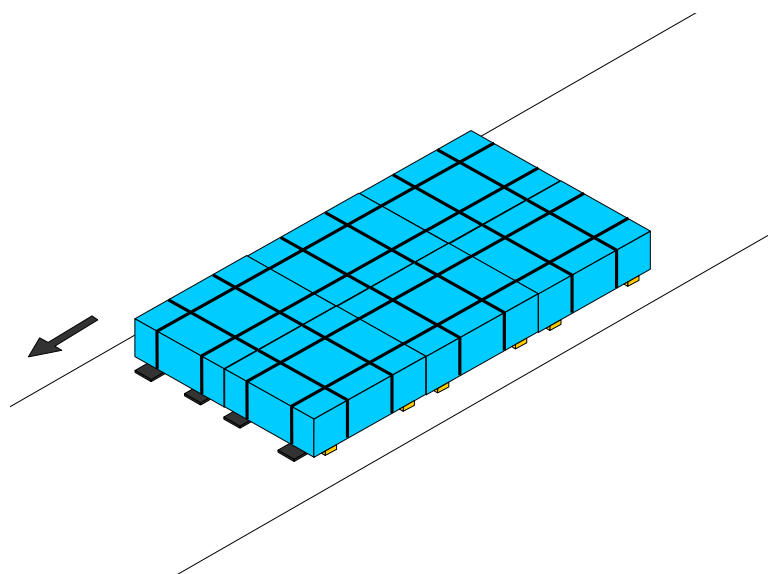

- The bundles will be loaded in blocks as large as possible, with a maximum of 25 tons per block.
- When the load consists of an odd number of bundles the last row is formed by a single and centrally placed bundle.
- Axle weights must be taken into account when placing the bundles.
- When stanchions are used or a block is placed against the headboard, no space must be left between the bundles and the stanchions or headboard to make sure the bundles are locked in forward direction.

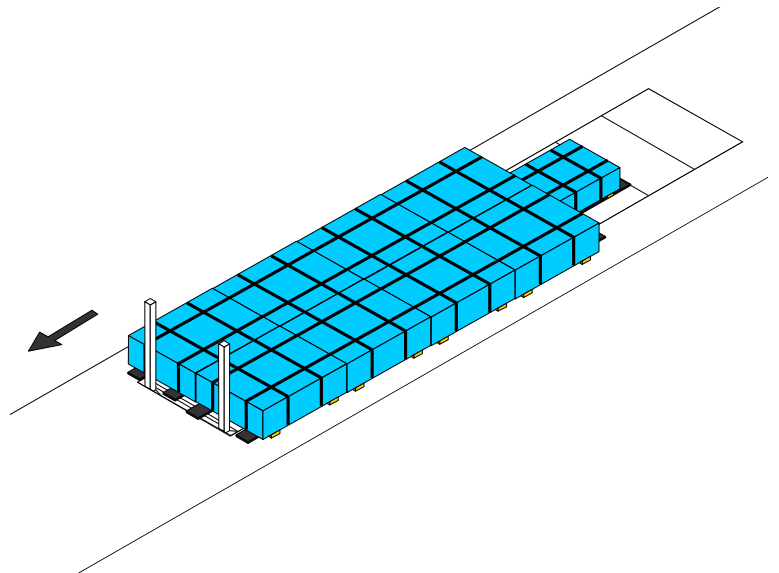

Securing

- Every pair of bundles must be secured with at least one strap.
- The straps must be placed over the bundles so the straps remain on the bundles even after a small movement of the bundles.
- Edge protectors must be used between the edges of the bundle and the strap.

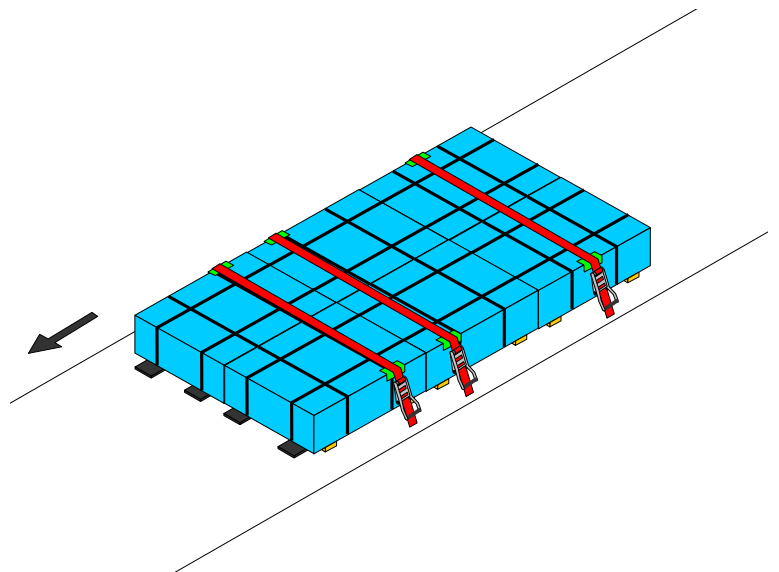

- A single bundle is lashed in a similar way as a double row.

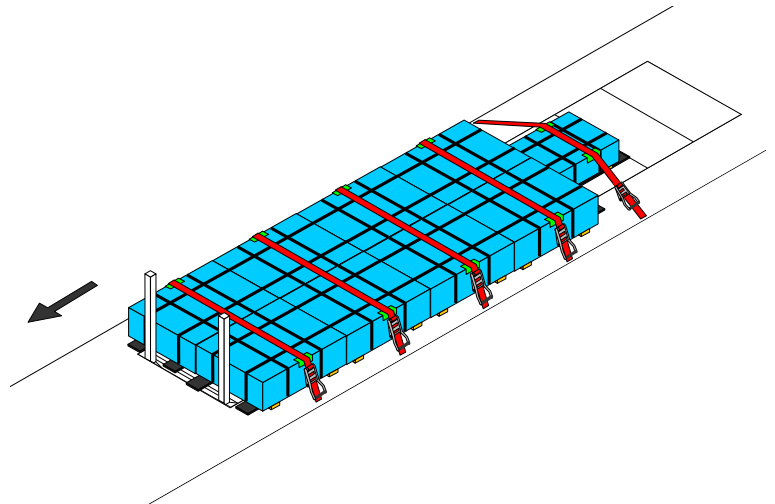

- Every block not placed against the headboard or stanchions must also be secured with a corner lashing.

- The first strap of the corner lashing runs from the securing point next to the first bundle, under the corner of the bundle and then turns back over the bundles to a backward lying securing point on the opposite side of the trailer.

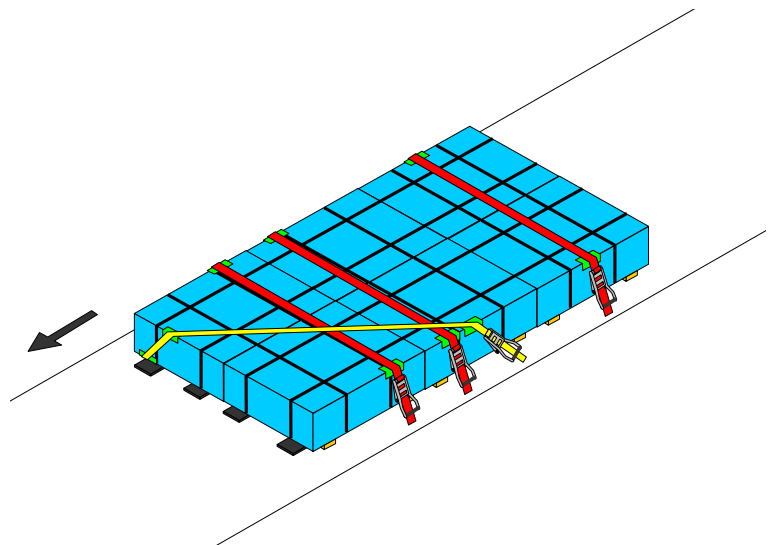

- Edge protectors must be used between the edges of the bundle and the strap.

- The second strap of the corner lashing is applied like the first strap, but on the opposite side of the trailer.

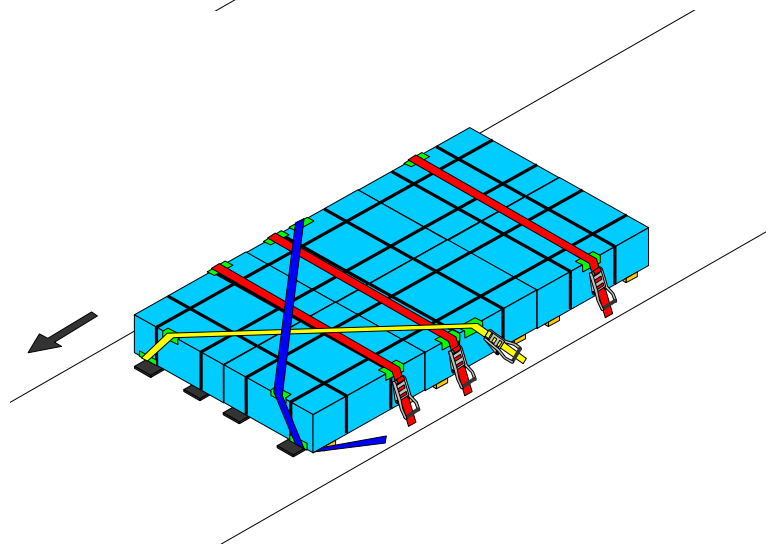

- The load restraint method described in this document is designed to be compliant with the forces as specified in EN12195-1: 2003 and VDI 2700.

4.4 Return Cargo

4.4.1 Packaging

- Whenever possible the returning of Tata Steel material should be done in the original packaging. The packaging must be removed when it affects the safe transport of the material.
 - Due to safety reasons broken banding must always be replaced prior to transport.
- Horizontal coils must be transported on a suitable coil well trailer or using a cradle or stillages in case of a flat trailer bed. See 2.3.5/6 for the requirements of cradles and stillages.
- Unused ETTS coils should be placed on a ETTS pallet when possible. When this is not possible the coil must be transported on a wooden/steel ETTS pallet. The TSP sales department can arranged for this pallet to be provided.
- For TSP material there is a separate information sheet available for the preparation for coils that are to be returned to Tata Steel.

4.4.2 Securing

- Return loads must be secured as described in this document in Section 4 - Securing methods.

Blank page

5. Organisation and management

5.1 Application

5.1.1 Responsibility

- Carriers are responsible for providing safe and damage-free transport. This document describes the minimum requirements. It does not relieve carriers from responsibility for taking additional measures as he may deem necessary. Carriers retain full liability.

5.1.2 Application

- These regulations apply for all road transports departing in continental Europe under responsibility of or ordered by Tata Steel Europe in IJmuiden.
- These regulations also apply for all road transports outside continental Europe when agreed so with the service provider.
- These regulations do not include all onsite warehouse and dispatch regulations. For these local regulations dedicated arrangements will be provided.

5.1.3 Standards

- The load restraint methods and guidelines described in this document are designed to be compliant with the forces as specified in EN12195-1: 2003 and VDI 2700.

5.1.4 Inspection

- Checks will be performed on the basis of our minimum requirements as described in parts 1 through to 4 of this document.
- Checks may be performed during loading, in transit or at the unloading location.
- Vehicles that do not meet the minimum requirements will be refused the load.
- If it is established that a driver has not secured the load in accordance with the regulations or has not the right securing equipment, the transport will be halted. The person who performs the check will decide whether the failing can be rectified. If

the carrier cannot meet the minimum requirements, the trailer will have to unload and leave empty.

5.1.5 Penalty Policy

- Tata Steel works with a penalty policy wherein deviations in relation to the regulations are handled through a so called none conformance system.
- The none conformance system rates a violation with an 'C' category for a minor violation up to a 'A' for a major violation.
- The registered none conformances have a validity of 1 year.
- The none conformances are assigned when the deviation is culpable.
- None conformances can lead to a suspension of a driver or haulier for Tata Steel transports for a (in)definite period of time.

5.2 Document Control

5.2.1 Publication method

- The Quality and Transport Safety Department (QTS) of Logistics & Transport (LT) of Tata Steel is charged with the publication of the Road Regulations.
- QTS will maintain a record of the publication of the controlled copies so that amendments can be made in all relevant departments.
- The current version of the Road Regulations will be available on a Tata Steel internet site anytime on the URL: <http://www.tatasteel.nl/veiligheid/en>.
- Under Regulations > Transport en logistics > Road Regulations.

5.2.2 Validity

- This document remains valid for a maximum period of 24 months, but can be amended when necessary.

5.2.3 Archive

- Records of the Road Regulations will be archived for at least 3 years.
- Authorisations will be archived until they are replaced by a new authorisation about the same piece of the Road Regulations.

5.2.4 Authorisation

- QTS will consult and inform all relevant departments and the forwarder when intending an alteration.
- QTS will present every amendment to the QTS Manager for authorization.

5.2.5 Change list

Terminated

- Road Regulations securing method for Coil in the Well (Replaced by Tata Steel Europe Load Restraint Guideline).

Changed

- Part 1 split into three Parts:- Part 1, Site access/procedures, Part 2, Equipment requirements and Part 3, Co-loads.
- Change of Penalty Point System to None Conformance System (6.1.5).
- Extension of possible checking of drivers personal protection equipment whilst on the Tata Steel IJmuiden site (1.2).
- Requirements for personal protection equipment according to their respective Euro Norms. (1.2).
- Requirement for well angle (2.2.4).
- Minimal distance between Tata Steel product and co-loads (2.2.4).
- Inclusion of haulier equipment into co-load requirements (Part3).
- Identification of co-loads using the GHS hazard symbols (3.1).
- Identification of load residue as possible contamination source (3.1).
- Change of Securing Methods layout to Tata Load Restraint Guideline format (Part 4).

New

- Technical Information Sheets for haulier equipment requirements including Web lashings, Chain lashings, Edge protection, Well boards and Anti-slip matting (2.4).
- Tata Steel Europe Load Restraint Guide Line For Wide Coil in the Well (Part 4).
- Appendices for Technical Advice Specific Equipment documents as required (Part 6).

6. Appendices

6.1 Technical advice documents / Specific equipment documents