

TECHNICAL ADVICE DOCUMENT

Llanwern Tops & Bottoms using chains

1. This Technical Advice Document applies to

- The transportation of Tops & Bottoms from Llanwern Heavy Gauge.
- Typical product length of 4 metres.

The lowest friction factor is determined to be $\mu=0.27$.

2. Essential requirements

- Product must **NOT** be loaded above the headboard or side post heights.
- The headboard must be rated to 7.5 tonnes or above, or approved by Tata Steel Load Restraint Engineers.
- Loads must be placed on a single layer of timber dunnage with a minimum cross-section of 100 mm x 100 mm.
- Low friction products must have Anti-slip matting placed on top of all base timber dunnage.
- All restraints must be a minimum 8 mm Grade 8, LC 40 kN chains compliant with EN 12195-3.
- Minimum lashing point rating of 3 tonnes, or suitable side raves as per *TIS-0009 Lashing Points*.
- Side pins must be fitted to all loads.
- If the rear stack is distorted in such a way that there is insufficient blocking in the forward direction, then cross-over restraints must be added.

3. Load configuration and restraint

3.1 Option 1 - Loaded to the headboard

- ✓ Load up to the headboard.
- ✓ Square base timbers evenly distributed.
- ✓ Anti-slip matting on top of all base timbers for low friction products.
- ✓ Maximum gap of 50 mm between stacks.

8 mm Grade 8 LC 40 kN ✓

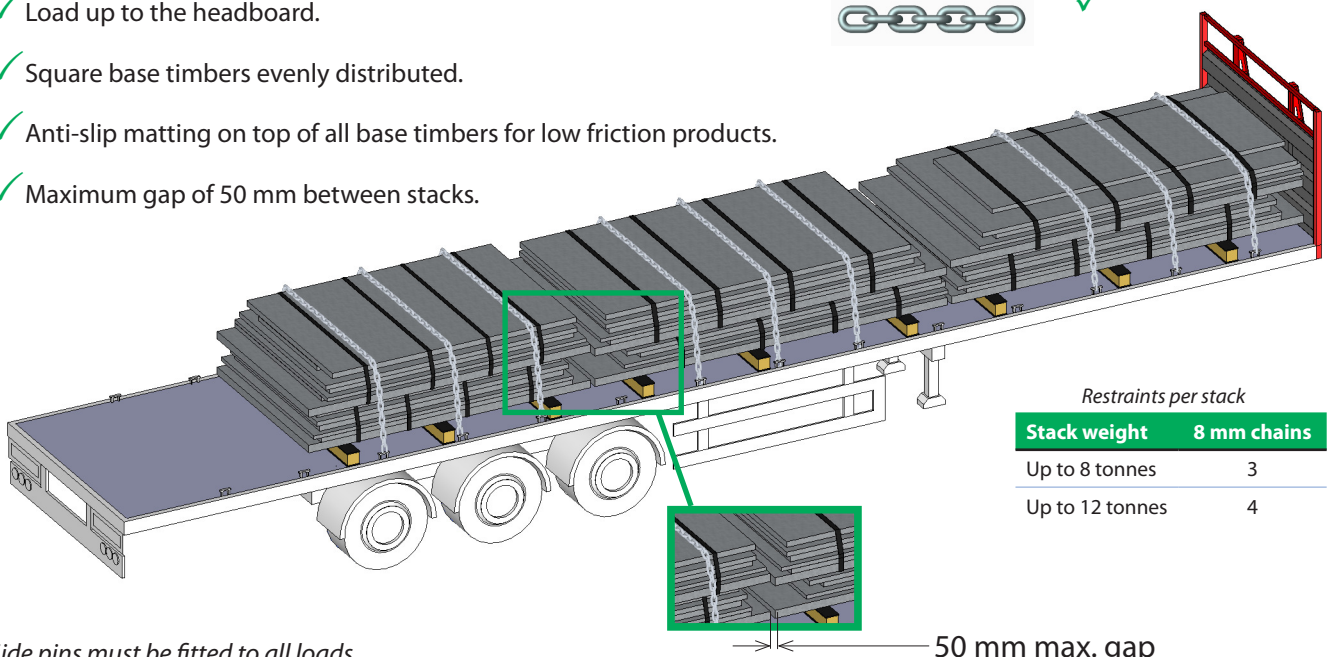

Restraints per stack

Stack weight	8 mm chains
Up to 8 tonnes	3
Up to 12 tonnes	4

Side pins must be fitted to all loads

50 mm max. gap

TECHNICAL ADVICE DOCUMENT

Llanwern Tops & Bottoms using chains

3.2 Option 2 - Cross-over chains

Any part of the load that is loaded away from the headboard **must** have cross-over restraints applied.

- ✓ A minimum of 8 mm LC 40 kN chains for **ALL** restraints.
- ✓ Anti-slip matting on top of all base timbers for low friction products.
- ✓ Front edges of the product must be aligned vertically.
- ✓ 3 **over-the-top** restraints per stack.

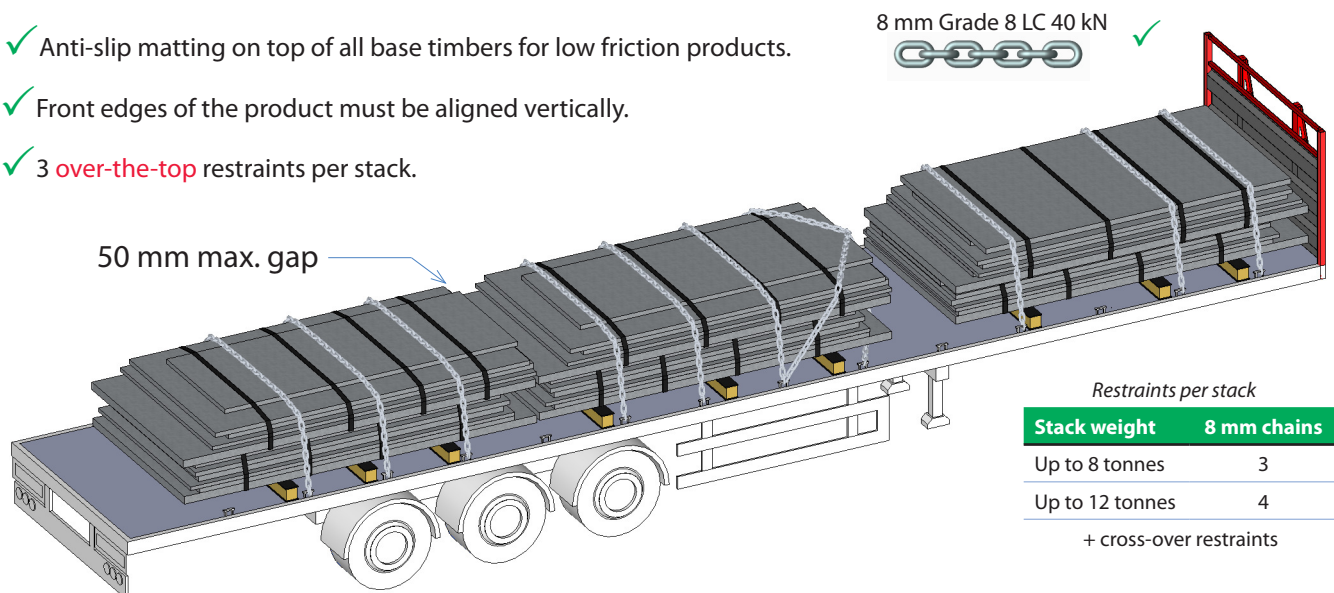

Side pins must be fitted to all loads

4. Severe winter weather advisory periods

- During severe winter weather periods, additional measures are required.
- ✓ One additional **over-the-top** restraint must be added to each stack.



5. Cross-over application

A pair of cross-over chains must be applied to the rear stack if there is excessive distortion in the sale plate.

- 2 cross-over chains are required around the front of the rear stack.
- Rating of lashing points must be a minimum of 5 tonnes.

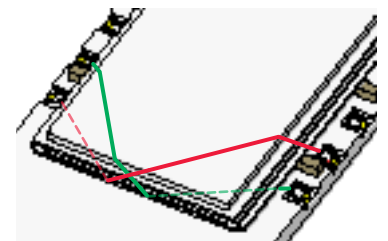

6. Headboard requirements

- Trailers with headboards rated to 7.5 tonnes or above, or approved by Tata Steel Load Restraint Engineers, or trailers with headboards manufactured to EN 12642 Code XL, can be loaded with product blocked to the trailer headboard to provide forward restraint.
- If the headboard strength cannot be verified, the headboard will require lashing back with a minimum 8 mm Grade 8 LC 40 kN chain (as shown)

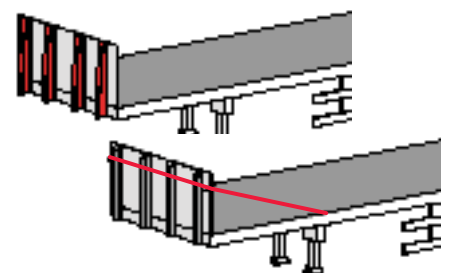

Care has been taken to ensure that the contents of this publication are accurate, but Tata Steel Europe Limited and its subsidiaries do not accept responsibility or liability for errors or information that is found to be misleading.